

# Submersible Mixer

Here you will find technical documentation for Landia mixers in the form of schematic drawing, service instructions and more.

Please click on the links below "table of contents" to get the information needed.

## Table of contents

### POP-I/POPR-I

Schematic drawing

Principal measurements

Technical data sheet

Service instruction



### POPL-I

Schematic drawing

Principal measurements

Technical data sheet

Service instruction



### POD-I/PODR-I

Schematic drawing

Principal measurements

Technical data sheet

Service instruction



### Oil-/Conversion table

Oil table

Conversion table

### Elektric data

Elektric data 400V-50 Hz IE1

Elektric data 400V-50 Hz IE2

Elektric data 400V-50 Hz IE3

COPYRIGHT - This drawing is the property of Landia A/S and cannot be shown, copied, given to a third party or used in any other way without permission from Landia A/S.

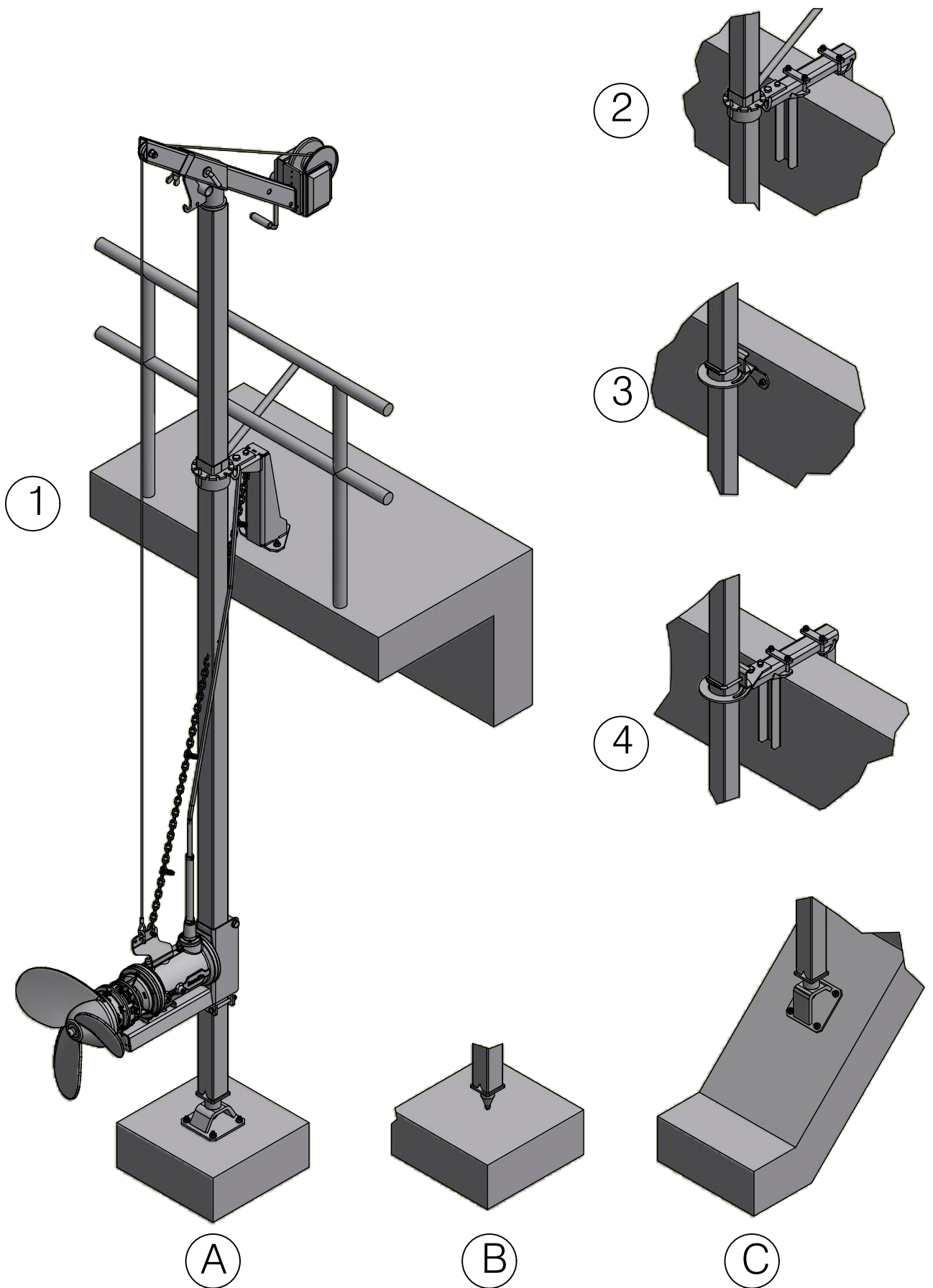

Styret dokument

**Landia**

POP-I 300 rpm / UPM / t.m.  
Betondækbefæstelser. Concrete fixings  
Beton Befestigung. Fixation sur beton

Scale: 1 : 20	Sign.: HL   KSK	Date: 04-07-2007
Dwg.no.:		3740541
Revision date: 31-07-2017		

COPYRIGHT - This drawing is the property of Landia A/S and cannot be shown, copied, given to a third party or used in any other way without permission from Landia A/S.

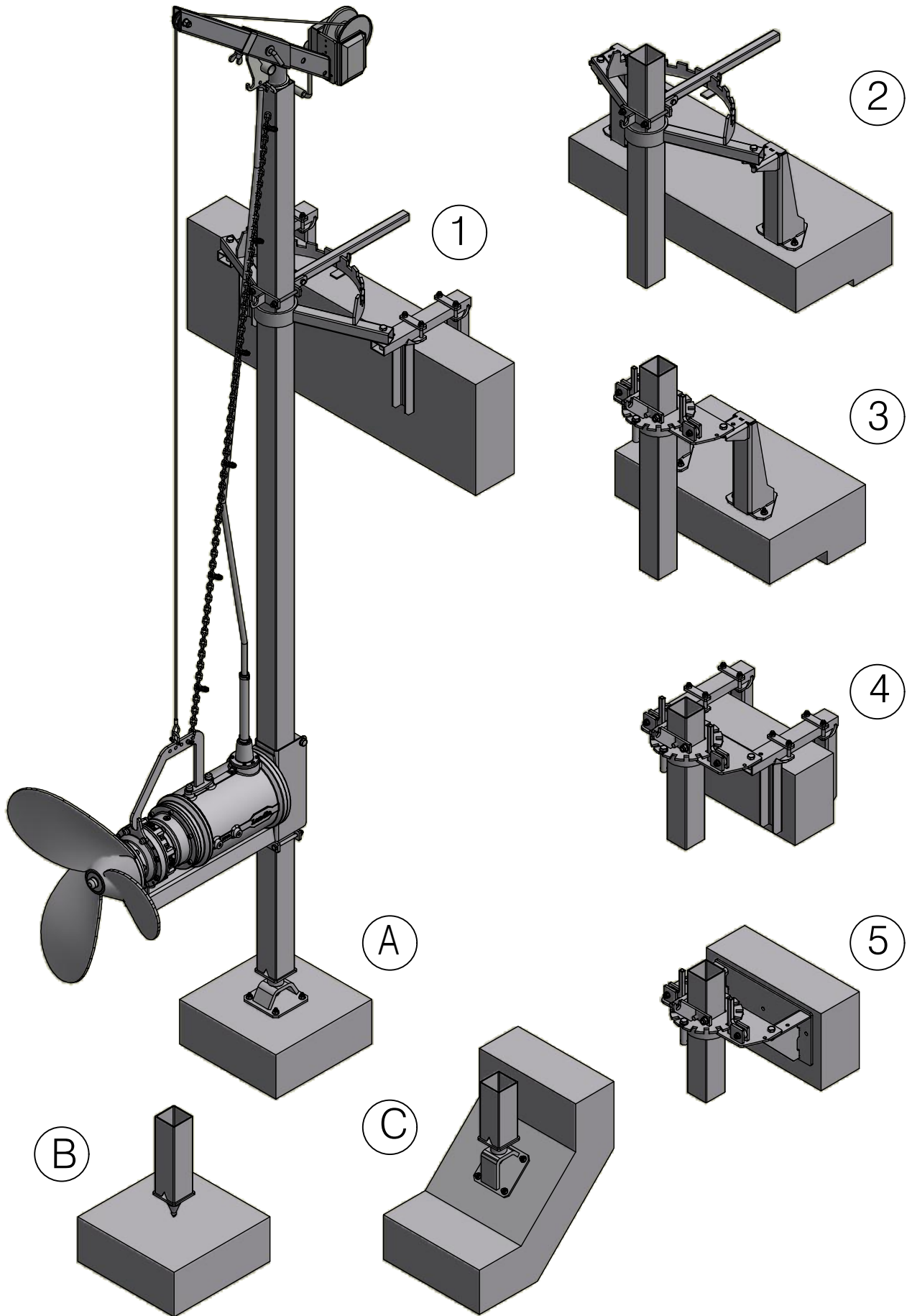

Styret dokument

**Landia**

POP-I 300 rpm / UPM / t.m.  
Betonbefæstelser. Concrete fixings  
Beton Befestigung. Fixation sur beton

Scale: 1 : 20	Sign.: HL   KSK	Date: 22-08-1996
Dwg.no.:		3740542
Revision date: 31-07-2017		

COPYRIGHT - This drawing is the property of Landia AS and cannot be shown, copied, given to a third party or used in any other way without permission from Landia AS.

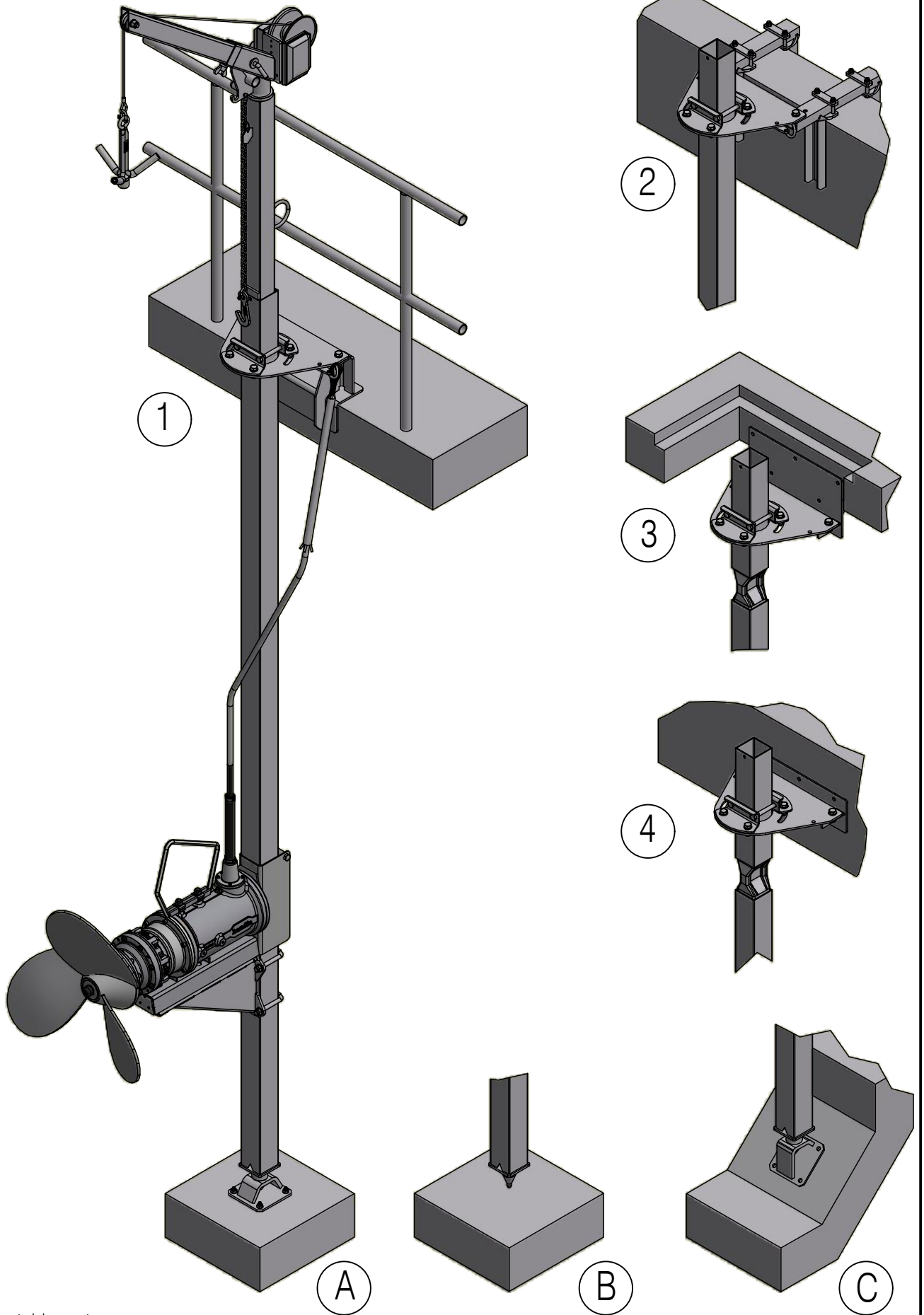

Styret dokument

**Landia**<sup>®</sup>

POP-I  
Betonbefæstelser, Concrete fixings  
Beton Befestigung, Fixation sur beton

Scale: 1 : 20	Sign.: LBO   KSK	Date: 11-07-2007
Dwg.no.:		3740531
Revision date: 09-10-2019		



COPYRIGHT - This drawing is the property of Landia AS and cannot be shown, copied, given to a third party or used in any other way without permission from Landia AS.

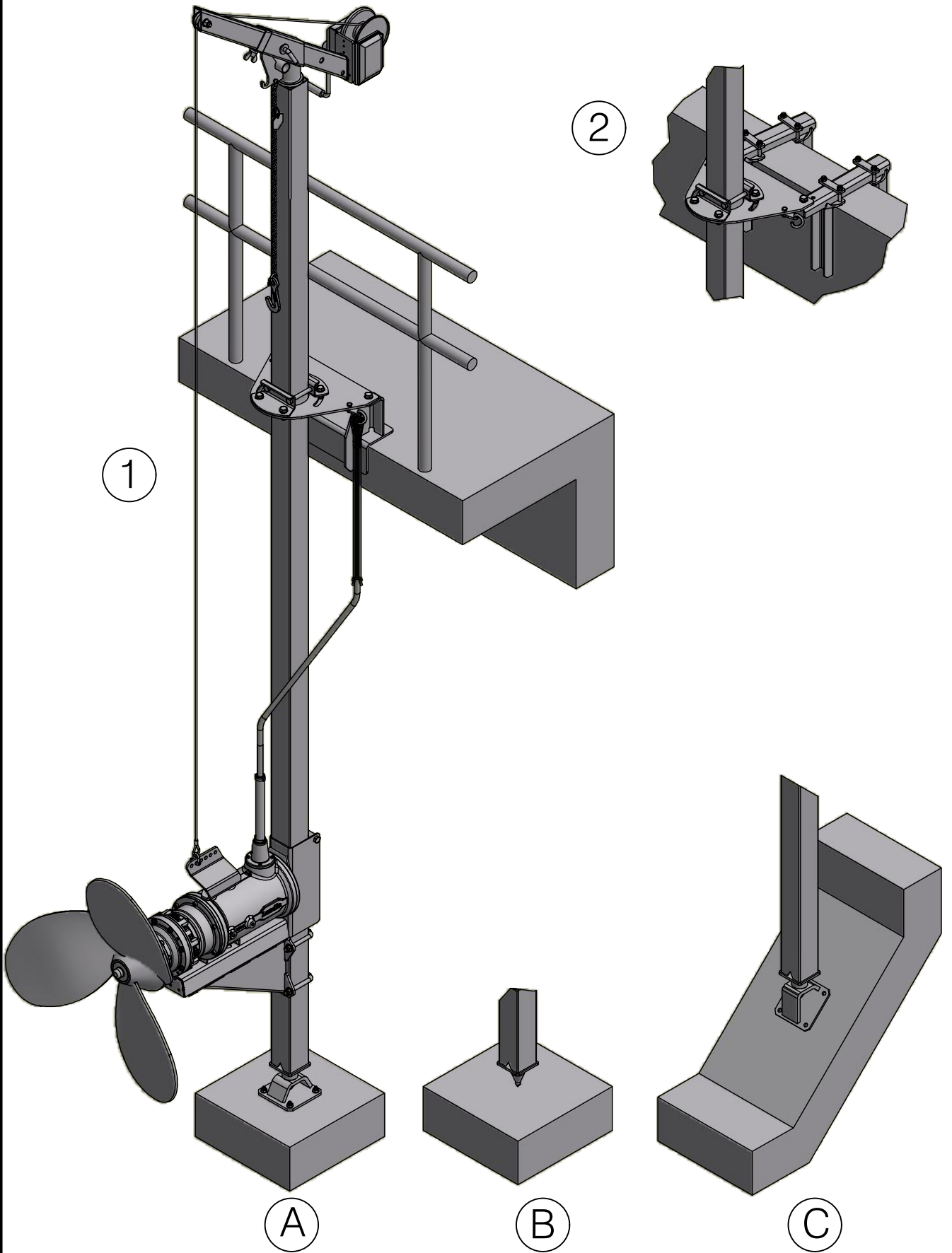

Styret dokument

**Landia**

POP-I 150 rpm / UPM / t.m.  
Betonbefæstelser, concrete fixings  
Beton Befestigung, Fixation sur beton

Scale:	Sign.:	Date:
1 : 20	HL   KSK	11-07-2007
Dwg.no.:		3740540
Revision date: 31-07-2017		

COPYRIGHT - This drawing is the property of Landia AS and cannot be shown, copied, given to a third party or used in any other way without permission from Landia AS.



**Landia**<sup>®</sup>

POP-I 300 rpm / UPM / t.m.  
Tværdrager. Crossbeam  
Querbalken. Fixation sur traverse

Scale:	Sign.:	Date:
1 : 20	ESK   KSK	12-07-2007
Dwg.no.:		3740565
Revision date: 31-07-2017		

COPYRIGHT - This drawing is the property of Landia AS and cannot be shown, copied, given to a third party or used in any other way without permission from Landia AS.

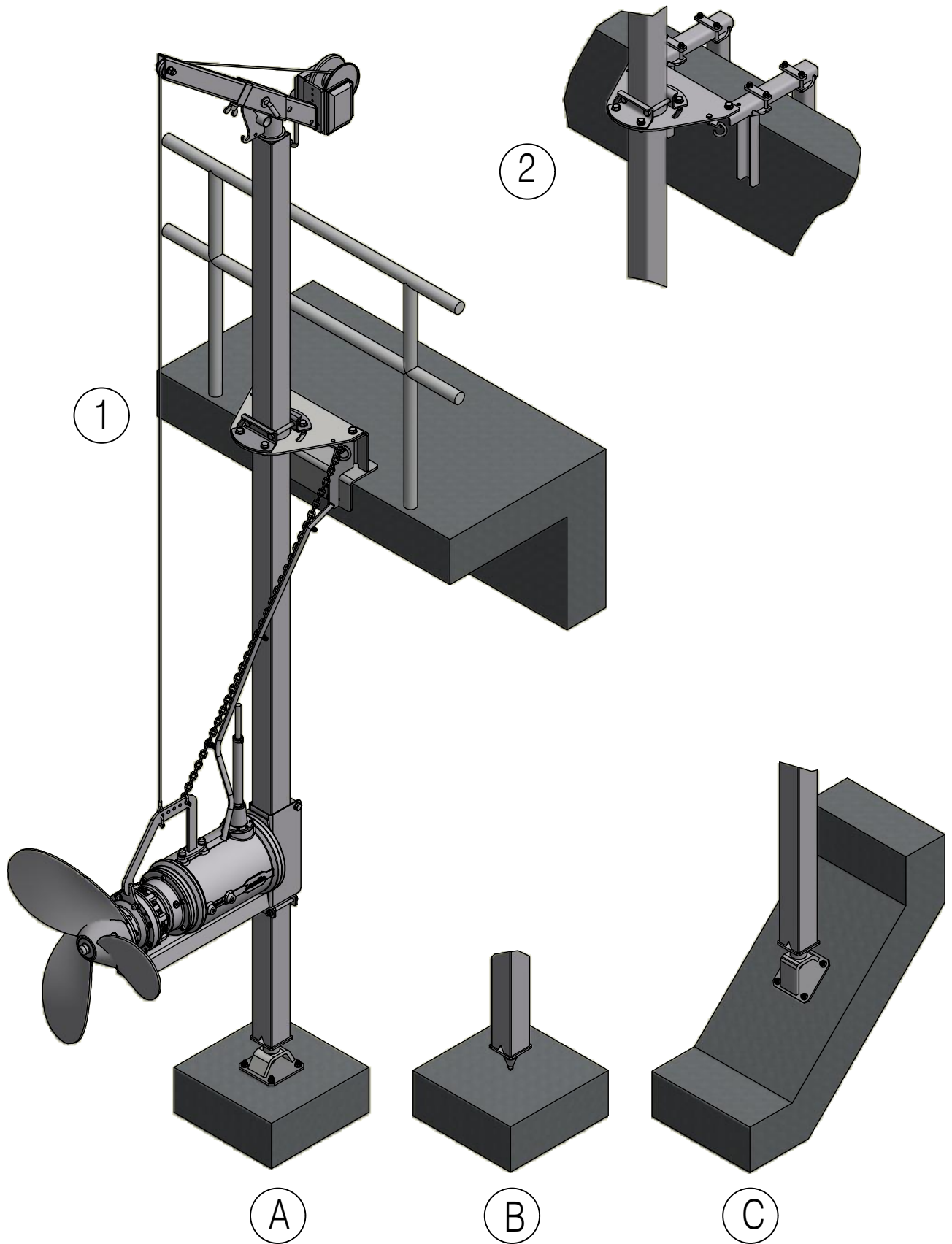

Styret dokument

**Landia**

POP-I 300 rpm / UPM / t.m.  
Betonbefæstelser. Concrete fixings  
Beton Befestigung. Fixations sur beton

Scale:	Sign.:	Date:
1 : 20	HL   KSK	13-07-2007
Dwg.no.:		3740551
Revision date: 31-07-2017		

COPYRIGHT - This drawing is the property of Landia A/S and cannot be shown, copied, given to a third party or used in any other way without permission from Landia A/S.

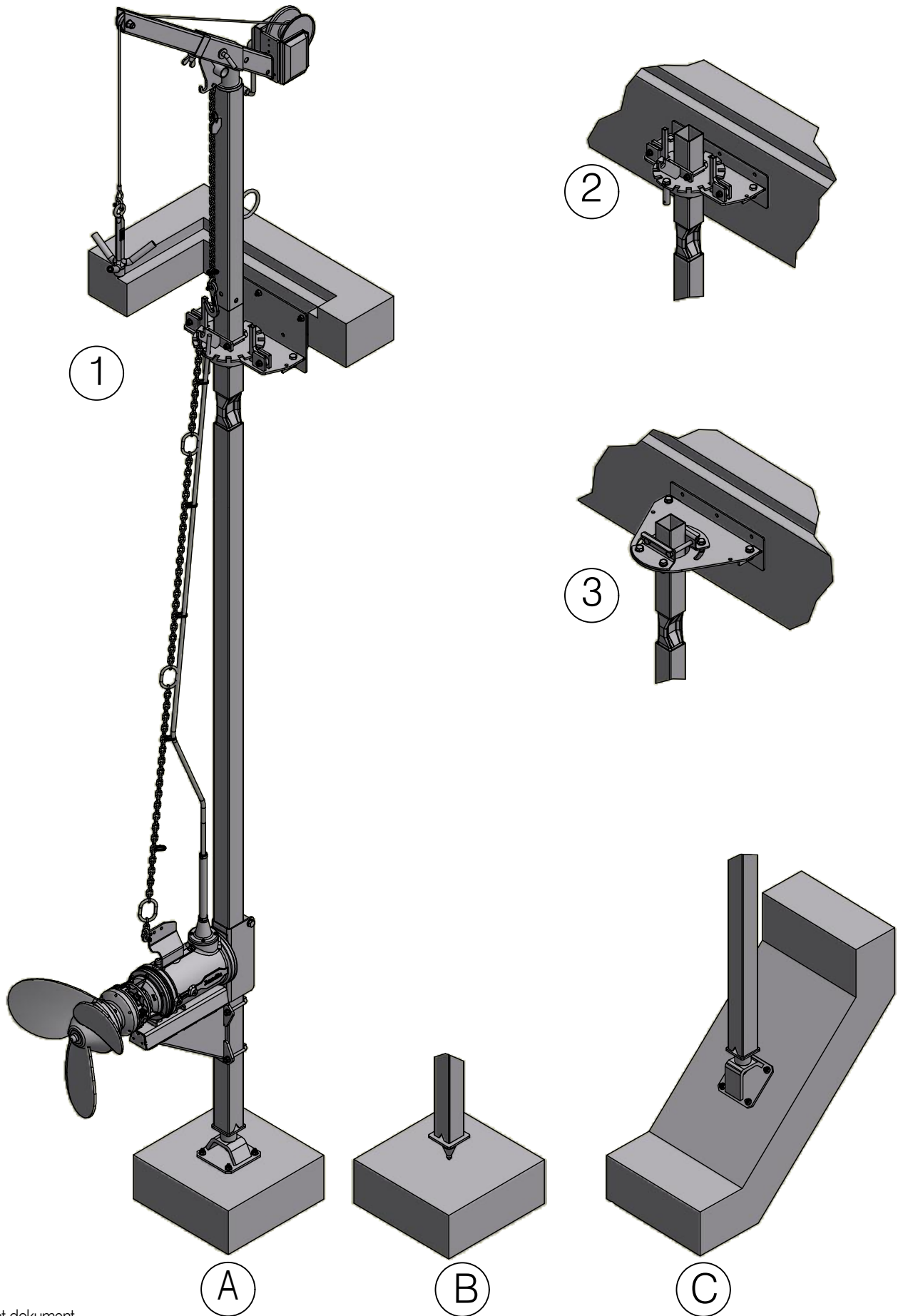

Styret dokument

**Landia**<sup>®</sup>

POP-I 300 rpm / UPM / t.m.  
Befæstelse under dæk. Below cover  
Unter Behälterdecke. Sup. sous couvercle

Scale:	Sign.:	Date:
1 : 20	HL   KSK	02-12-2016
Dwg.no.:		3740635
Revision date: 31-07-2017		

COPYRIGHT - This drawing is the property of Landia AS and cannot be shown, copied, given to a third party or used in any other way without permission from Landia AS.

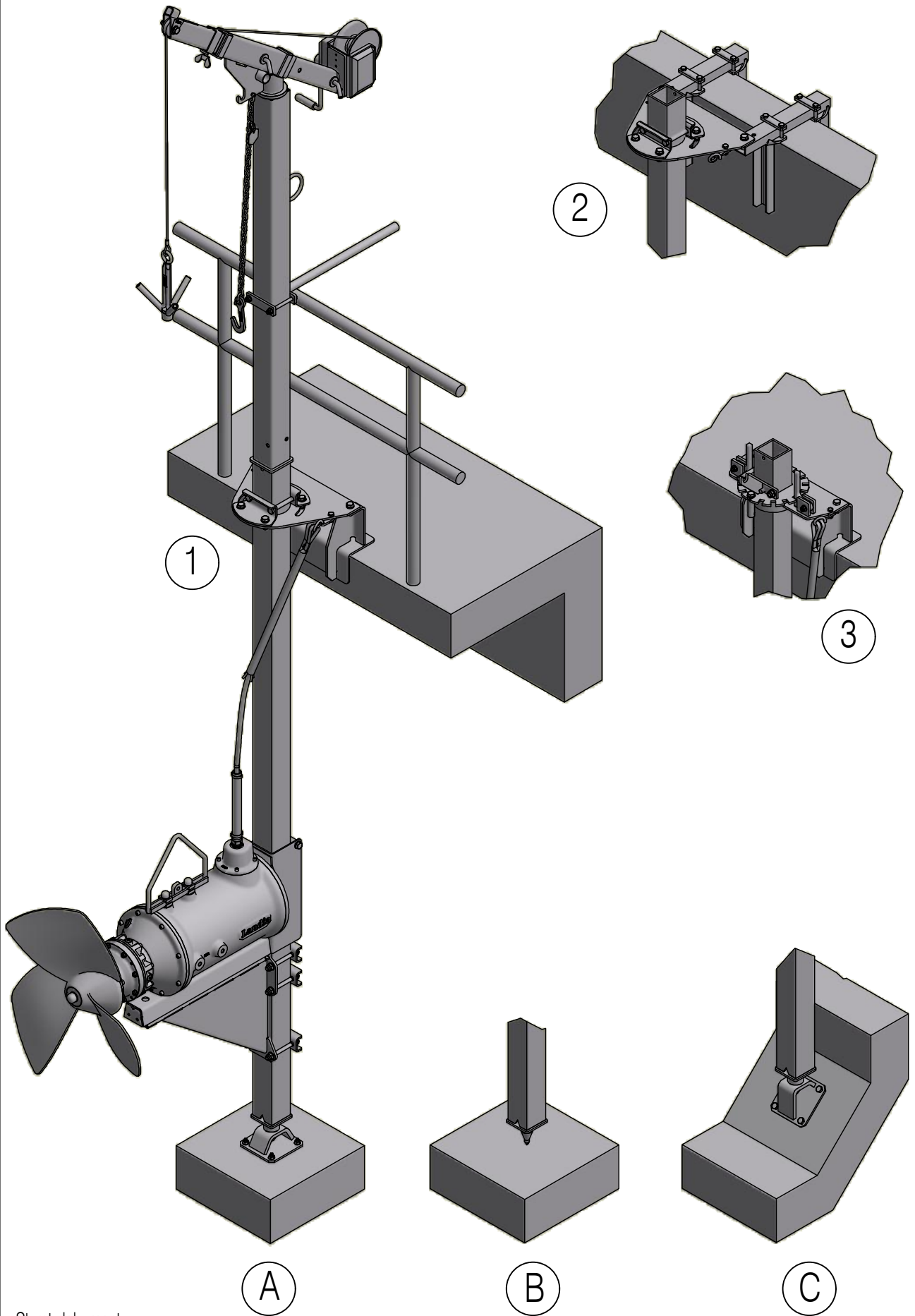

Styret dokument

**Landia**

POP-I ms.180  
Betonbefæstelse, concrete fixing  
Beton Befestigung, Fixation sur beton

Scale: 1 : 20	Sign.: NLA   KSK	Date: 18-06-2015
Dwg.no.:		3740922
Revision date: 31-07-2017		



COPYRIGHT - This drawing is the property of Landia AS and cannot be shown, copied, given to a third party or used in any other way without permission from Landia AS.

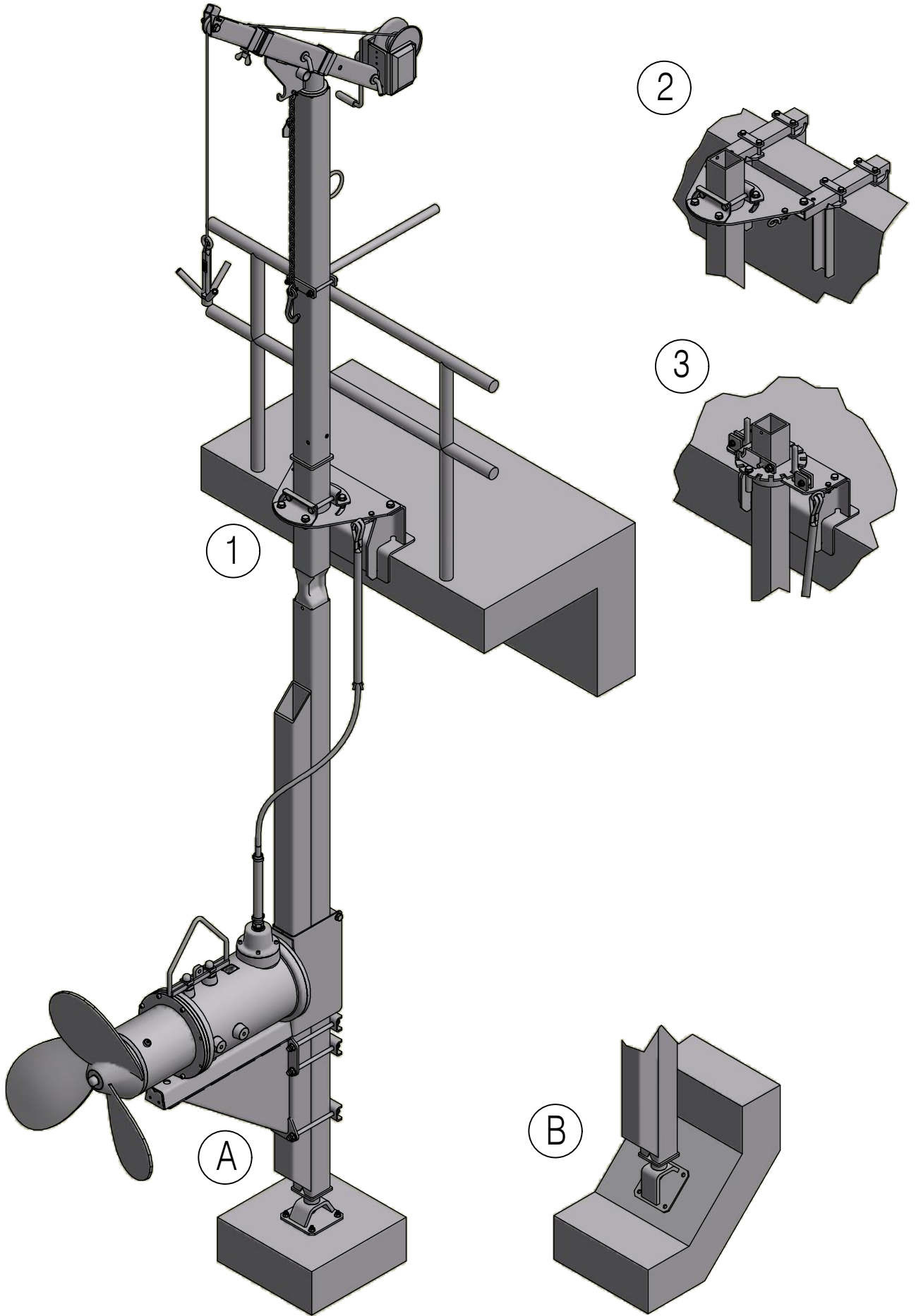

Styret dokument

**Landia**

POPR-I ms.180  
Betonbefæstelser, concrete fixings  
Beton Befestigung, Fixation sur beton

Scale:	Sign.:	Date:
1 : 20	BNV   KSK	31-05-2016
Dwg.no.:		3740931
Revision date: 31-07-2017		

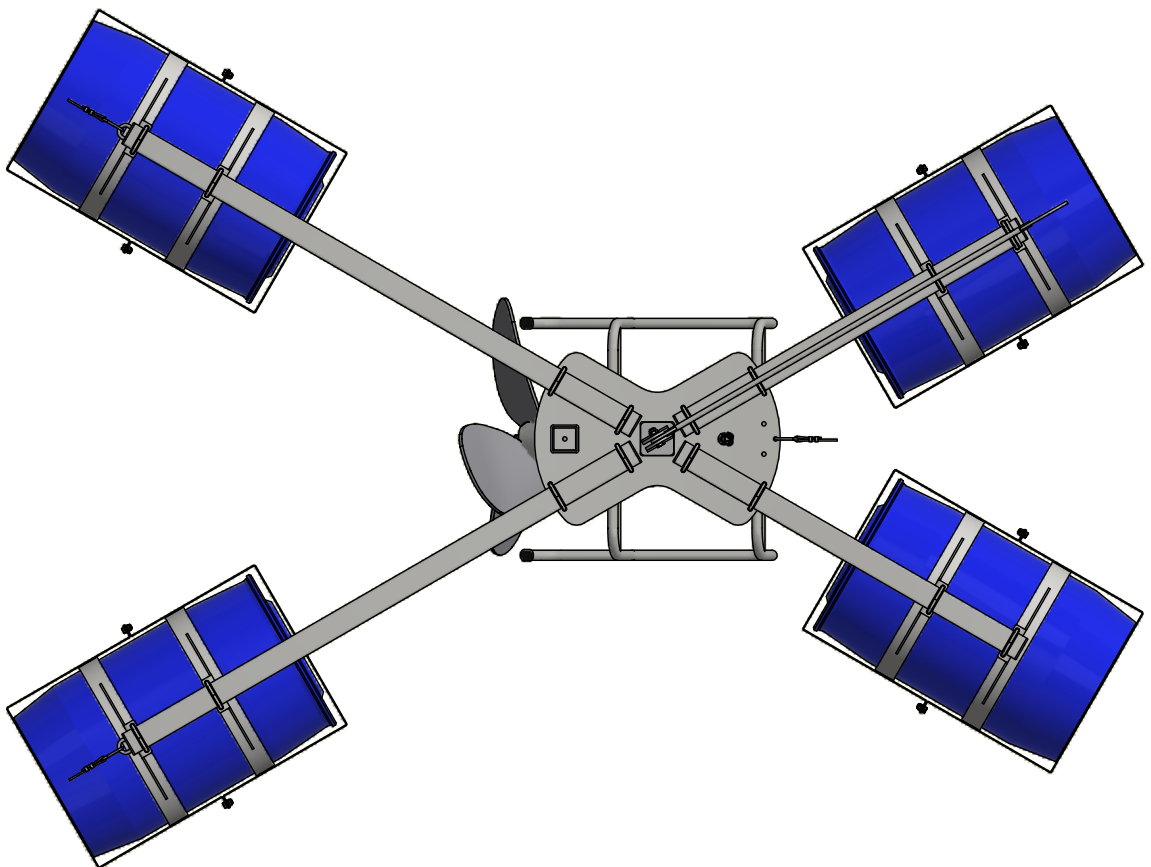
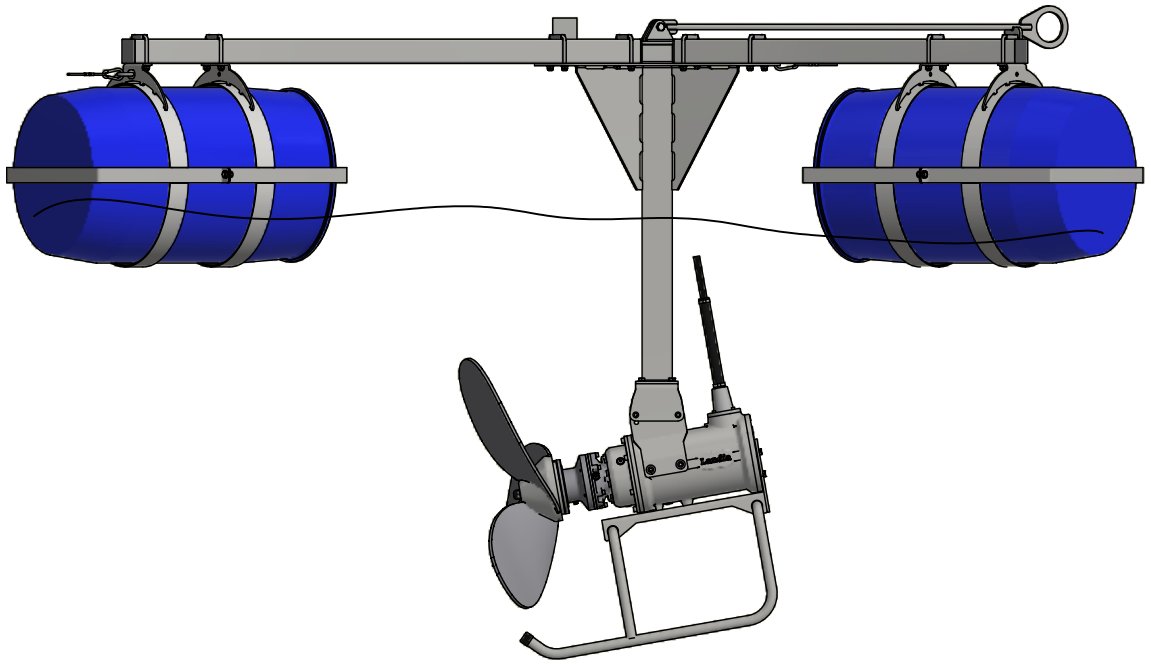

COPYRIGHT - This drawing is the property of Landia A/S and cannot be shown, copied, given to a third party or used in any other way without permission from Landia A/S.

Styret dokument

**Landia**

POP-I ms.112 - ms.160  
 m/flydeponton, w/Pontoon  
 m/Ponton, a/flotteur

Scale: 1 : 20	Sign.: HL   KSK	Date: 13-08-2007
Dwg.no.:		3740772
Revision date: 01-07-2021		

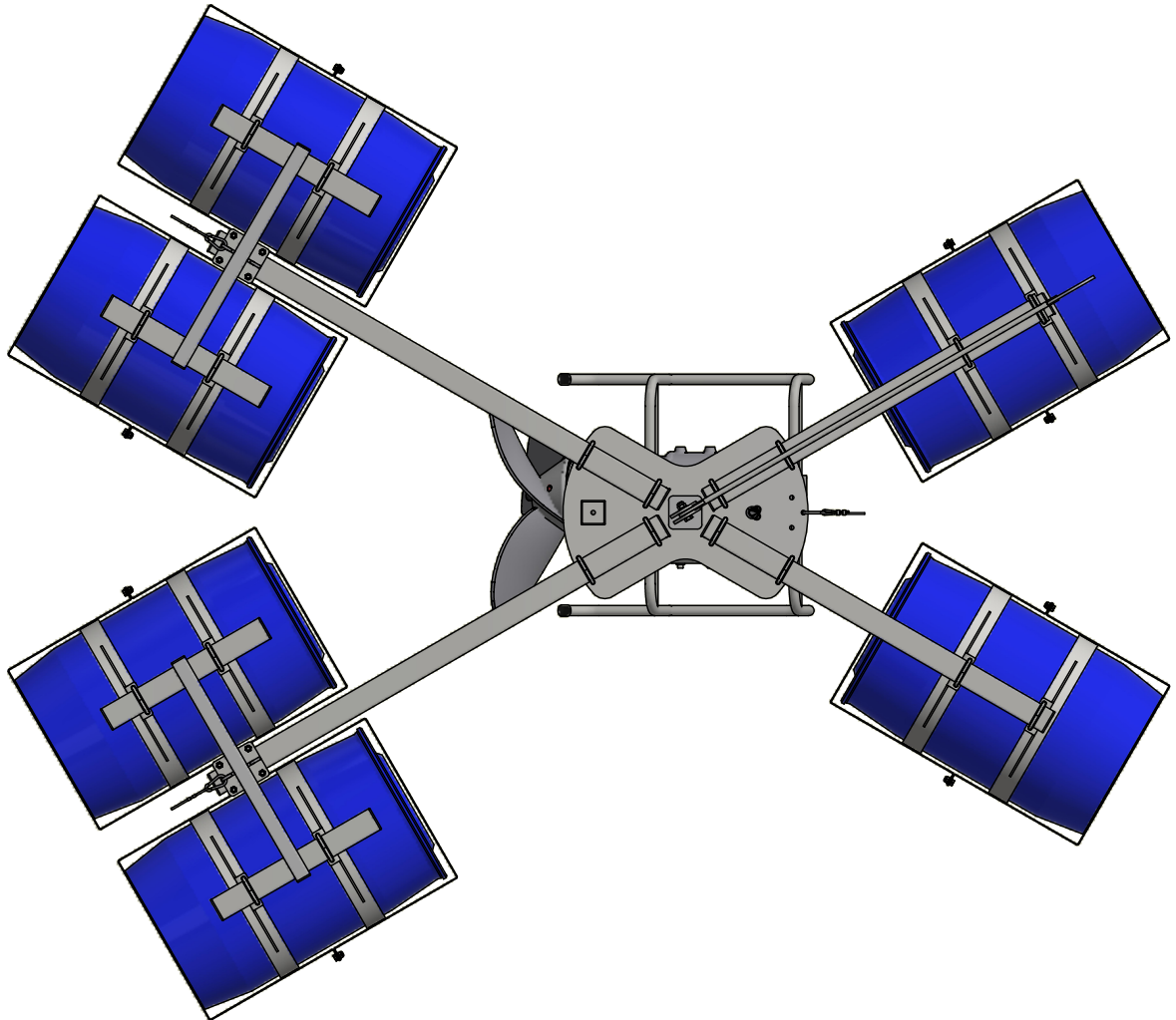
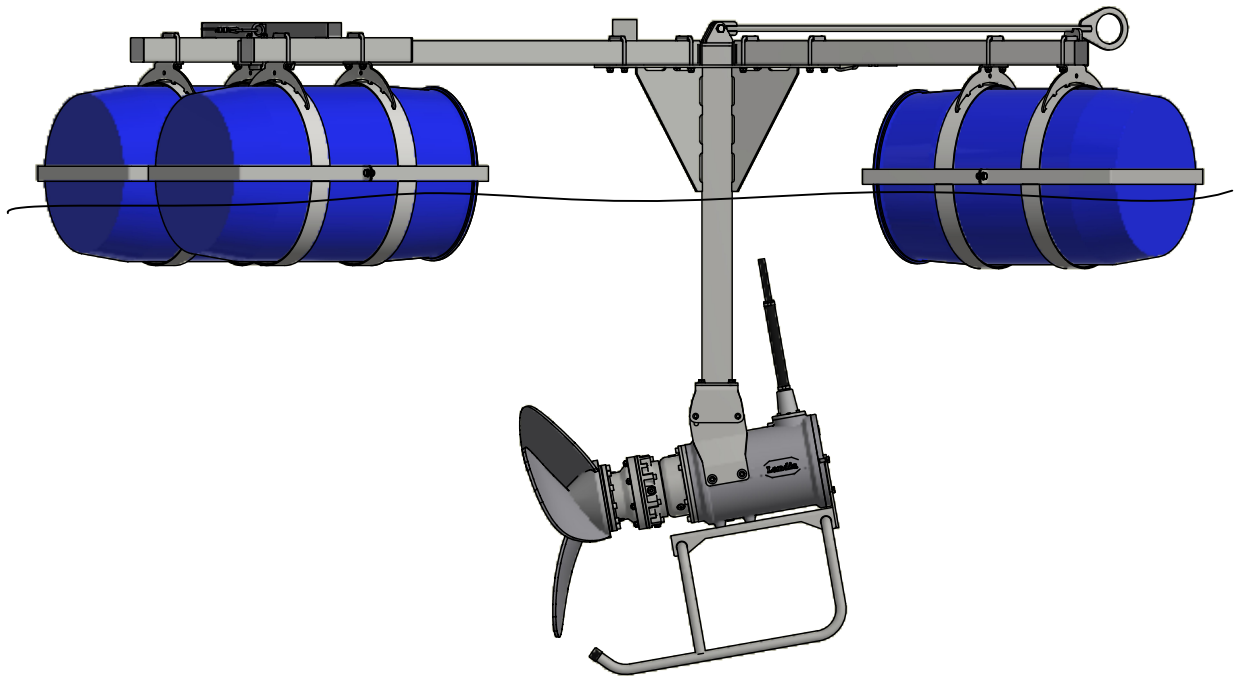

Styret dokument

COPYRIGHT - This drawing is the property of Landia A/S and cannot be shown, copied, given to a third party or used in any other way without permission from Landia A/S.

**Landia**

POP-I 300 rpm / UPM / t.m. ms.160  
 m/flydeponton, w/Pontoon  
 m/Ponton, a/flotteur

Scale:	Sign.:	Date:
1 : 25	HL   KSK	13-08-2007
Dwg.no.:		3740777
Revision date: 01-07-2021		

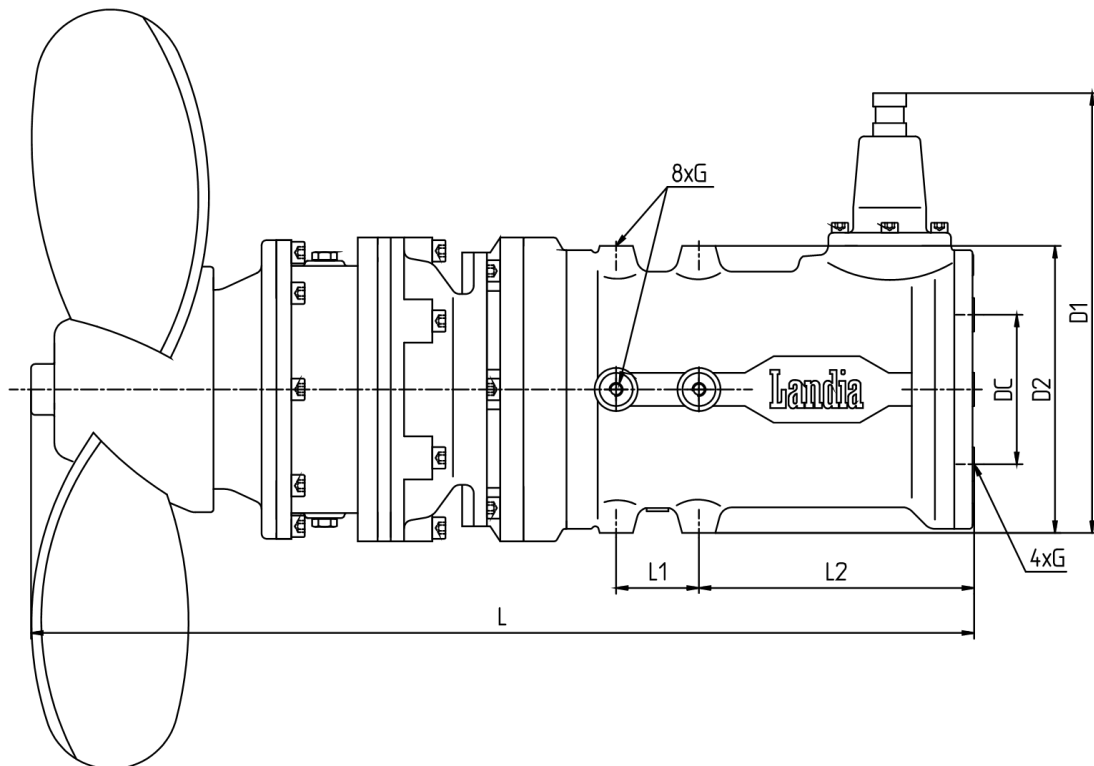
**POP-I IE1**

Varenr. Article no. Artikel Nr. Code no. (400V)	Effekt Power Leist. Puiss. [kW]	Serie Series Baureihe Série ms.	Prop.omdr. Prop.rpm. Prop.Drehzahl Hélice tours [rpm]	Prop.diam. Prop.diam. Prop.Durchm. Diam. Hélice [mm]	L [mm]	L1 [mm]	L2 [mm]	DC [mm]	D1 [mm]	D2 [mm]	G [mm]				
1118398	1,1	100	150	ø620	740	75	203,5	120	320	213	M10				
1118301	1,5	100		ø730	750										
1118302	2,2	112		ø845	820										
1118303	3,0	112		ø900	830	80	230	130	330	226					
1118304	4,0	132		ø930	922										
1118305	5,5	132		ø1030	955										
1118307	7,5	160		ø1080	1050	100	276,5	200	440	318					
1114398	1,1	80	300	ø365	625						50	166	90	265	173
1114301	1,5	80		ø410											
1114302	2,2	90		ø450	55	100	280	189							
1114303	3,0	100		ø490	715				75	203,5	120	320	213		
1114304	4,0	100		ø575	735										
1114305	5,5	112		ø620	802	80	230	130	330	226					
1114307	7,5	132		ø660	877										
1114311	11,0	132		ø770	905	100	255	150	385	264					
1114315	15,0	160		ø840	950										
1114318	18,5	160		ø880	980										
1114324	22,0	180		400	ø770	1085	120	364,5	220	450	367	M16			
1114332	30,0														

Ret til tekniske ændringer forbeholdes - We reserve the right to make technical alterations.  
 Technische und maßliche Änderungen vorbehalten - Sous réserve de modifications techniques.

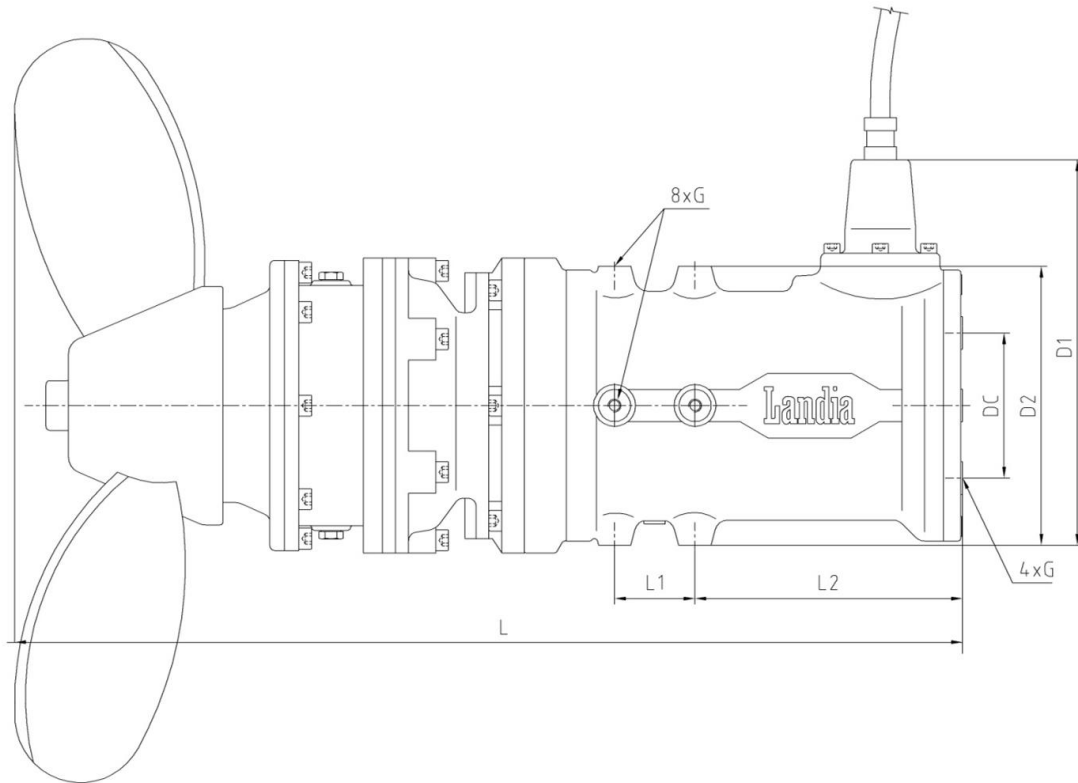
**POP-I IE2**

Varenr. Article no. Artikel Nr. Code no. (400V)	Effekt Power Leist. Puiss. [kW]	Serie Series Baureihe Série ms.	Prop.omdr. Prop.rpm. Prop.Drehzahl Hélice tours [rpm]	Prop.diam. Prop.diam. Prop.Durchm. Diam. Hélice [mm]	L [mm]	L1 [mm]	L2 [mm]	DC [mm]	D1 [mm]	D2 [mm]	G [mm]
1136301	1,1/0,75	100	150	ø620	740	75	203,5	120	305	213	M10
1136303	3,0/1,1	112		ø730	800	80	230	130	323,5	226	M10
				ø845	820						
				ø900	845						
1136304	4,0/3,0	132		ø930	935	100	255	150	364	264	M12
1136307	7,5/4,0	160		ø1030	1025	100	276,5	200	408	318	M12
			ø1150	1095							

Ret til tekniske ændringer forbeholdes - We reserve the right to make technical alterations.  
 Technische und maßliche Änderungen vorbehalten - Sous réserve de modifications techniques.

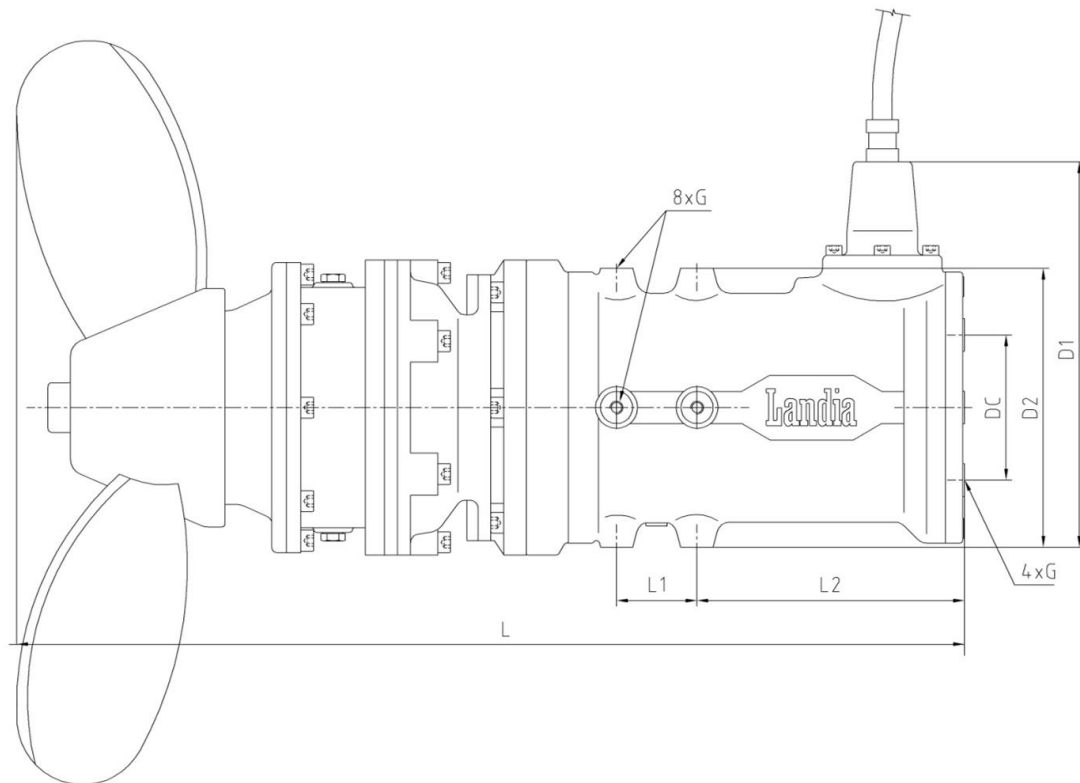

**POP-I IE3**

Varenr. Article no. Artikel Nr. Code no. (400V)	Effekt Power Leist. Puiss. [kW]	Serie Series Baureihe Série ms.	Prop.omdr. Prop.rpm. Prop.Drehzahl Hélice tours [rpm]	Prop.diam. Prop.diam. Prop.Durchm. Diam. Hélice [mm]	L [mm]	L1 [mm]	L2 [mm]	DC [mm]	D1 [mm]	D2 [mm]	G [mm]
1166304	4,0	132	150	ø930	935	100	255	150	364	264	M12
1166307	7,5	160		ø1150	1095	100	276,5	200	408	318	M12
1164301	1,5	100	300	ø410	715	75	203,5	120	305	213	M10
1164304	4,0	112		ø575	765	80	230	130	323,5	226	M10
1164307	7,5	132		ø660	915	100	255	150	364	264	M12
1164311	11,0	160		ø770	960	100	276,5	200	408	318	M12
1164318	18,5	180		ø880	1080	120	364,5	220	450	367	M16

Ret til tekniske ændringer forbeholdes - We reserve the right to make technical alterations.  
 Technische und maßliche Änderungen vorbehalten - Sous réserve de modifications techniques.

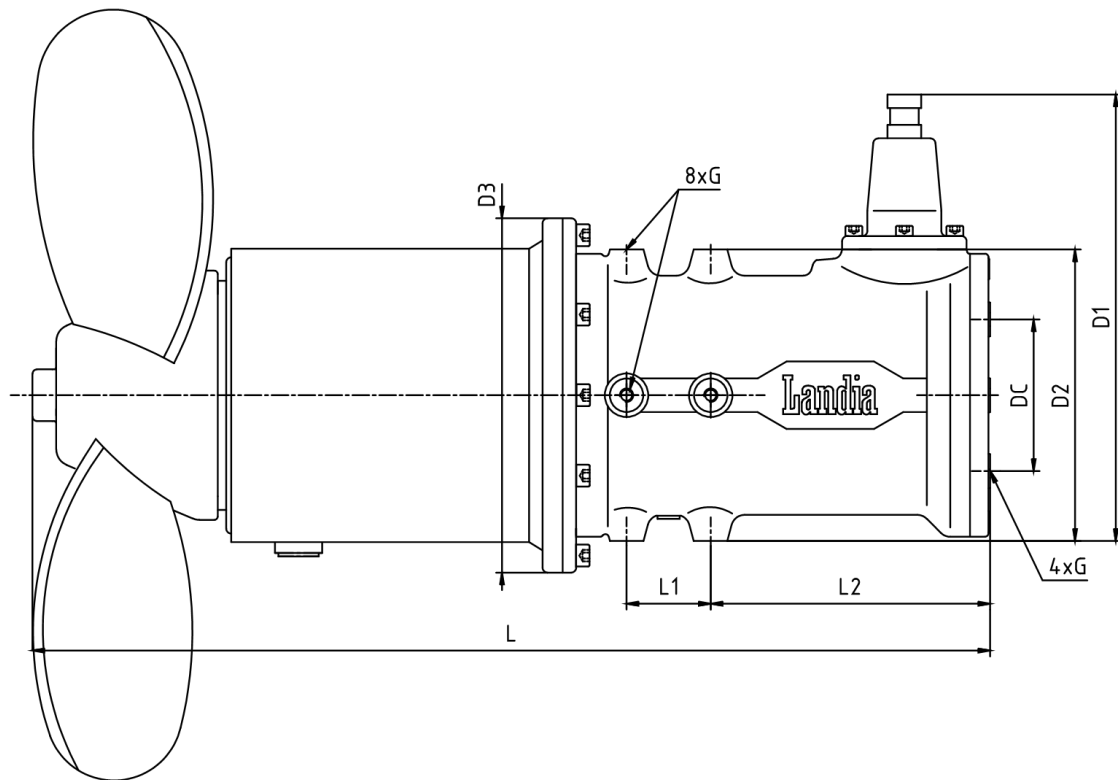
**POPR-I IE1**

Varenr. Article no. Artikel Nr. Code no. (400V)	Effekt Power Leist. Puiss. [kW]	Serie Series Baureihe Série ms.	Prop.omdr. Prop.rpm. Prop.Drehzahl Hélice tours [rpm]	Prop.diam. Prop.diam. Prop.Durchm. Diam. Hélice [mm]	L [mm]	L1 [mm]	L2 [mm]	DC [mm]	D1 [mm]	D2 [mm]	D3 [mm]	G [mm]	
1118298	1,1	100R	150	ø620	740	75	203,5	120	320	213	244	M10	
1118201	1,5			ø730	750								
1118204	4,0	132R		ø930	922	100		255	150	370	264	258	M12
1118205	5,5			ø1030	955								
1118207	7,5	160R		ø1080	1050	276,5		200	440	318	298		
1114203	3,0	100R		300	ø490	715		75	203,5	120	320	213	244
1114204	4,0		ø575		735								
1114207	7,5	132R	ø660		877	100	255	150		385	264	258	M12
1114211	11,0		ø770		905								
1114215	15,0	160R	ø840		950	276,5	200	440		318	298		
1114218	18,5		ø880		980								
1114223	22,0	180R	400	ø770	1085	120	364,5	220	450	367	350	M16	
1114231	30,0												

Ret til tekniske ændringer forbeholdes - We reserve the right to make technical alterations.  
 Technische und maßliche Änderungen vorbehalten - Sous réserve de modifications techniques.

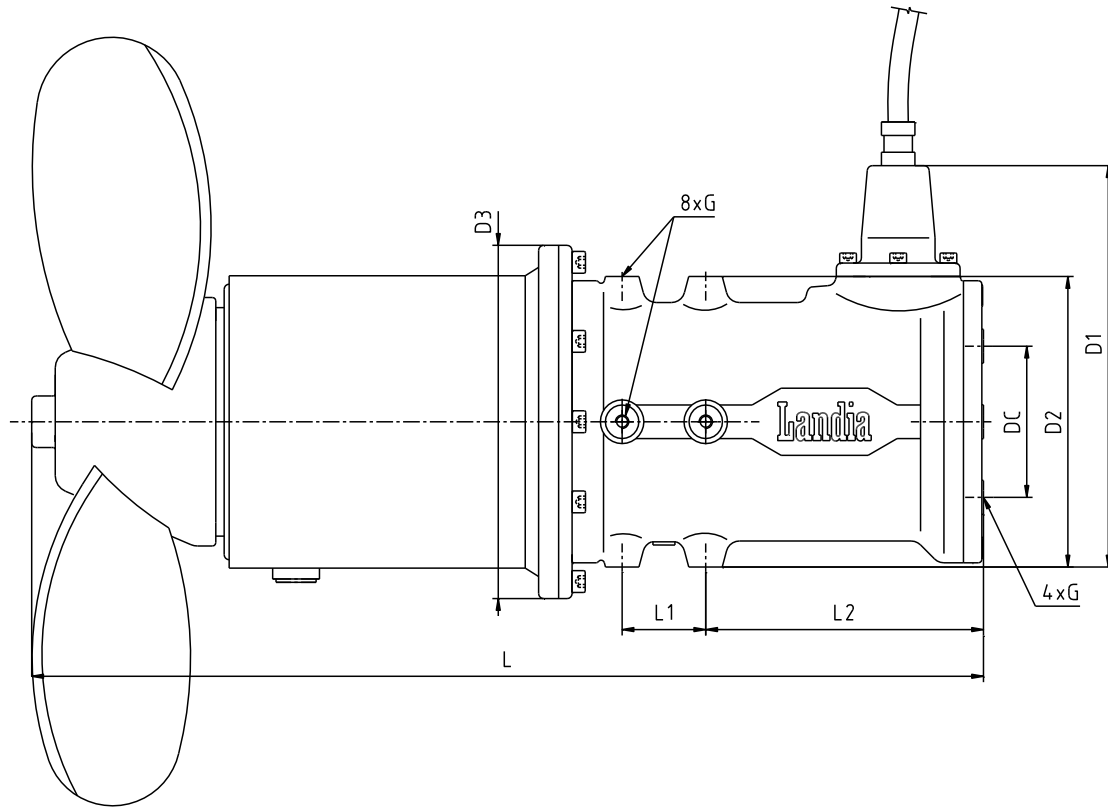
**POPR-I IE2**

Varenr. Article no. Artikel Nr. Code no. (400V)	Effekt Power Leist. Puiss. [kW]	Serie Series Baureihe Série ms.	Prop.omdr. Prop.rpm. Prop.Drehzahl Hélice tours [rpm]	Prop.diam. Prop.diam. Prop.Durchm. Diam. Hélice [mm]	L [mm]	L1 [mm]	L2 [mm]	DC [mm]	D1 [mm]	D2 [mm]	D3 [mm]	G [mm]
1136201	1,1/0,75	100R	150	ø620	740	75	203,5	120	305	213	244	M10
1136204	4,0/1,1	132R		ø730	885	100	255	150	364	264	258	M12
				ø845	910							
				ø900	935							
1136207	7,5/4,0	160R		ø1030	1010	276,5	200	408	318	298		
				ø1080	1050							

Ret til tekniske ændringer forbeholdes - We reserve the right to make technical alterations.  
 Technische und maßliche Änderungen vorbehalten - Sous réserve de modifications techniques.

**HOVEDMÅLSSKITSE POP-I MED FLYDEPONTON**  
**PRINCIPAL MEASUREMENTS, POP-I WITH PONTOON**  
**HAUPTMAßE POP-I MIT PONTON**  
**ENCOMBREMENTS POP-I AVEC FLOTTEUR**

Side 1/1

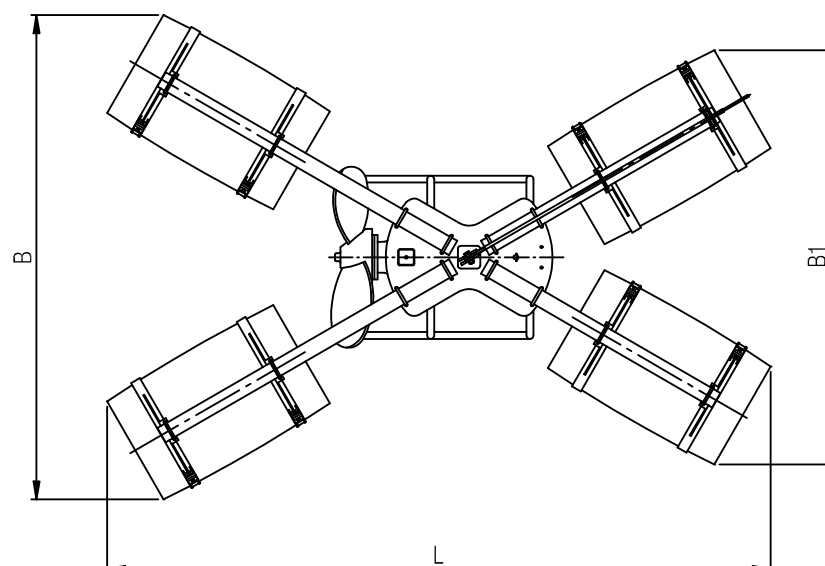
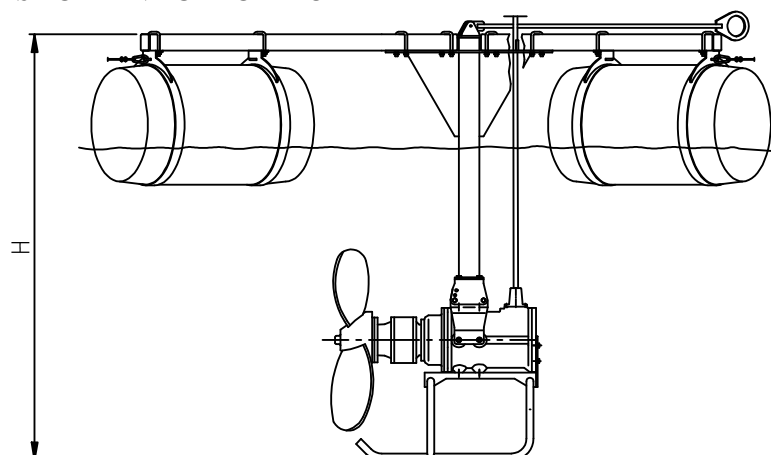

Varenr./ Article no./ Artikel Nr./ Code no.	Effekt/ Power/ Leist./ Puiss.	Serie/ Series/ Baureihe/ Série	Prop.omdr./ Prop.rpm./ Prop.Drehzahl/ Hélice tours	H	L	B	B1
(400V)	[kW]	ms.	[1/min]	[mm]	[mm]	[mm]	[mm]
1118303	3,0	112	150	2000	3225	2345	2015
1118304	4,0	132	150	2050	3225	2345	2015
1118305	5,5	132	150	2050	4005	3245	2015
1118307	7,5	160	150	2100	4440	3445	2315
1114305	5,5	112	300	2000	3315	2440	2015
1114307	7,5	132	300	2050	3315	2440	2015
1114311	11,0	132	300	2050	4180	3445	2015
1114315	15,0	160	300	2100	3680	3275	2015
1114318	18,5	160	300	2100	3680	3275	2015

Ret til tekniske ændringer forbeholdes- We reserve the right to make technical alterations.  
 Technische und maßliche Änderungen vorbehalten - Sous réserve de modifications techniques.

HOVEDMÅLSSKITSE POP-I IE2 MED FLYDEPONTON - PRINCIPAL MEASUREMENTS, POP-I IE2 WITH PONTOON  
 HAUPTMAßE POP-I IE2 MIT PONTON - ENCOMBREMENTS POP-I IE2 AVEC FLOTTEUR

Side 1/1

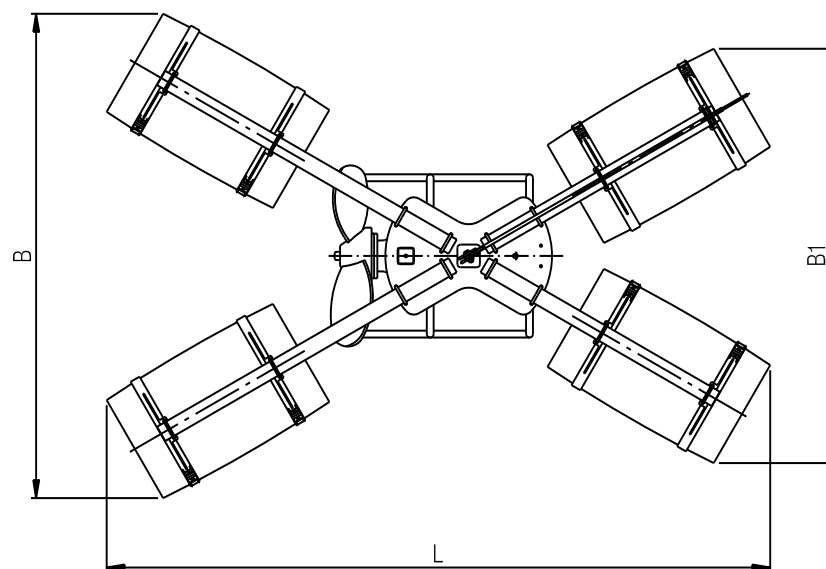
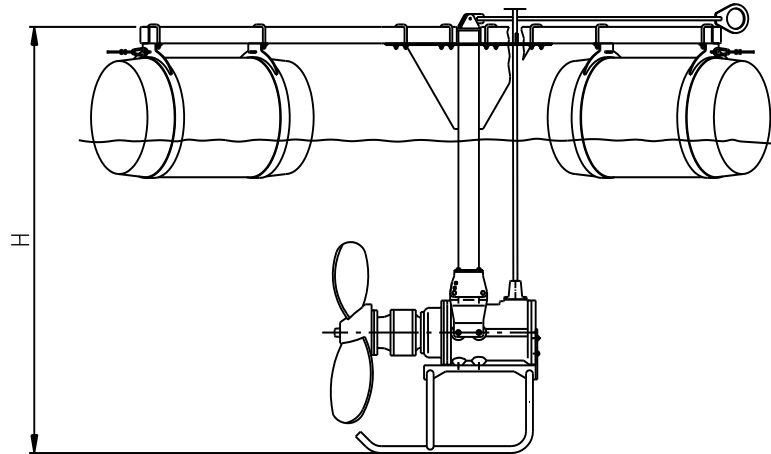

Varenr. Article no. Artikel Nr. Code no.	Effekt Power Leist. Puiss.	Serie Series Baureihe Série	Prop.omdr. Prop.rpm. Prop.Drehzahl Hélice tours	H	L	B	B1
(400V)	[kW]	ms.	[1/min]	[mm]	[mm]	[mm]	[mm]
1136303	3,0/1,1	112	150	2000	3225	2345	2015
1136304	4,0/3,0	132	150	2050	3225	2345	2015
1136307	7,5/4,0	160	150	2100	4440	3445	2315

Ret til tekniske ændringer forbeholdes - We reserve the right to make technical alterations.  
 Technische und maßliche Änderungen vorbehalten - Sous réserve de modifications techniques.



# POP-I

The Landia POP-I 150 is a slow-speed mixer for mixing and flow-making with a low energy consumption. This can, for example, be in aeration tanks or anaerobic tanks at sewage treatment plants.

The Landia POP-I 300/400 is a flexible and efficient mixer that is typically used for mixing liquids with a high dry matter content, such as dewatered sludge or biomass. The relatively low speed means that the POP-I 300 is the ideal mixer for highly viscous liquids.

## APPLICATION EXAMPLES

POP-I 150/300/400:

- ▶ Aeration tanks
- ▶ Oxidation ditches
- ▶ Anoxic and anaerobic tanks
- ▶ MBBR reactors

POP-I 300/400:

- ▶ Sludge with a high dry matter content
- ▶ Liquid biomass

## PROPELLER RPM

150 rpm – gear 1:6 or 1:7.25

300 rpm – gear 1:4.5 or 1:5

400 rpm – gear 1:3.55



**MATERIAL OF CONSTRUCTION POP-I 150 RPM**

Motor housing and oil chamber	Cast iron EN-GJL-250
Propeller	Steel W1.0038/S235JR Domex 700 (optional) Stainless steel W1.4301/AISI304 (optional) W1.4404/AISI316 (optional)
Gear	Cast iron EN-GJL-250
Output shaft gear	Shaft steel W1.6511/9840 (no contact with the liquid)
Bolts	A4
Exterior sealing system	3 oil sealing rings made of nitrile Stainless steel wear bush W1.4301/AISI304 (ceramic coating optional) Steel wear bush W1.2363/A2
Interior sealing system	Mechanical shaft seal: silicon carbide/silicon carbide
Oil type	Liquid temperature 0–30 °C SP 100 Liquid temperature 30–60 °C GS 220 GS 220 (with moisture detection)
Grease type	High temperature grease

**MATERIAL OF CONSTRUCTION POP-I 300/400 RPM**

Motor housing and oil chamber	Cast iron EN-GJL-250
Propeller	Steel W1.0038/S235JR Domex 700 (optional) Stainless steel W1.4301/AISI304 (optional) W1.4404/AISI316 (optional)
Gear	Cast iron EN-GJL-250
Output shaft gear	Shaft steel W1.6511/9840 (no contact with the liquid)
Bolts	A4
Exterior sealing system	1 oil sealing ring made of nitrile Wear bush made of stainless steel W1.4301/AISI304 (ceramic coating optional) Mechanical shaft seal: silicon carbide/silicon carbide
Interior sealing system	Mechanical shaft seal: silicon carbide/silicon carbide
Oil type	Liquid temperature 0–30 °C SP 100 Liquid temperature 30–60 °C GS 220 GS 220 (with moisture detection)
Grease type	High temperature grease

## SERVICE AND MAINTENANCE

Recommended service interval/oil change	Max. 4,300 operating hours/minimum once a year
Motor	Lifetime lubricated bearings
Gear	Periodic oil change Calculated service life >100,000 operating hours
Propeller	Periodic grease lubrication

## SURFACE TREATMENT

Machinery enamel: RAL 9005 (Jet Black)	Jet Black
2-component coating: RAL 7005 (Mouse Grey) (optional)	Mouse Grey

## ELECTRICAL CABLE

H07RN-F/S07RN-F EUCAFLEX<sup>Plus</sup> Cable.

Resistant to oil and UV radiation.

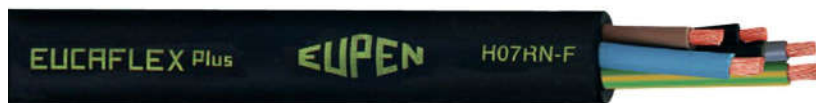

Number of conductors:

H07RN-F 7G1.5 mm<sup>2</sup> (Not used in United Kingdom)

H07RN-F 7G2.5 mm<sup>2</sup> (Only United Kingdom. Motor ≤ 5,5 kW)

S07RN-F 7G4+3x1.5 mm<sup>2</sup>

S07RN-F 7G6+3x1.5 mm<sup>2</sup>

As standard supplied with 7 m of cable (extra length available upon request).

## MONITORING FUNCTIONS

Bimetal thermal sensors 120 °C

Moisture detection system (optional)

## DESIGN POP-I 150 RPM

All Landia POP-I 150 mixers are delivered with a 1,000-rpm IE2 motor. A planetary gearbox reduces the number of propeller revolutions to 150, which gives a high propeller efficiency, resulting in a low energy consumption.

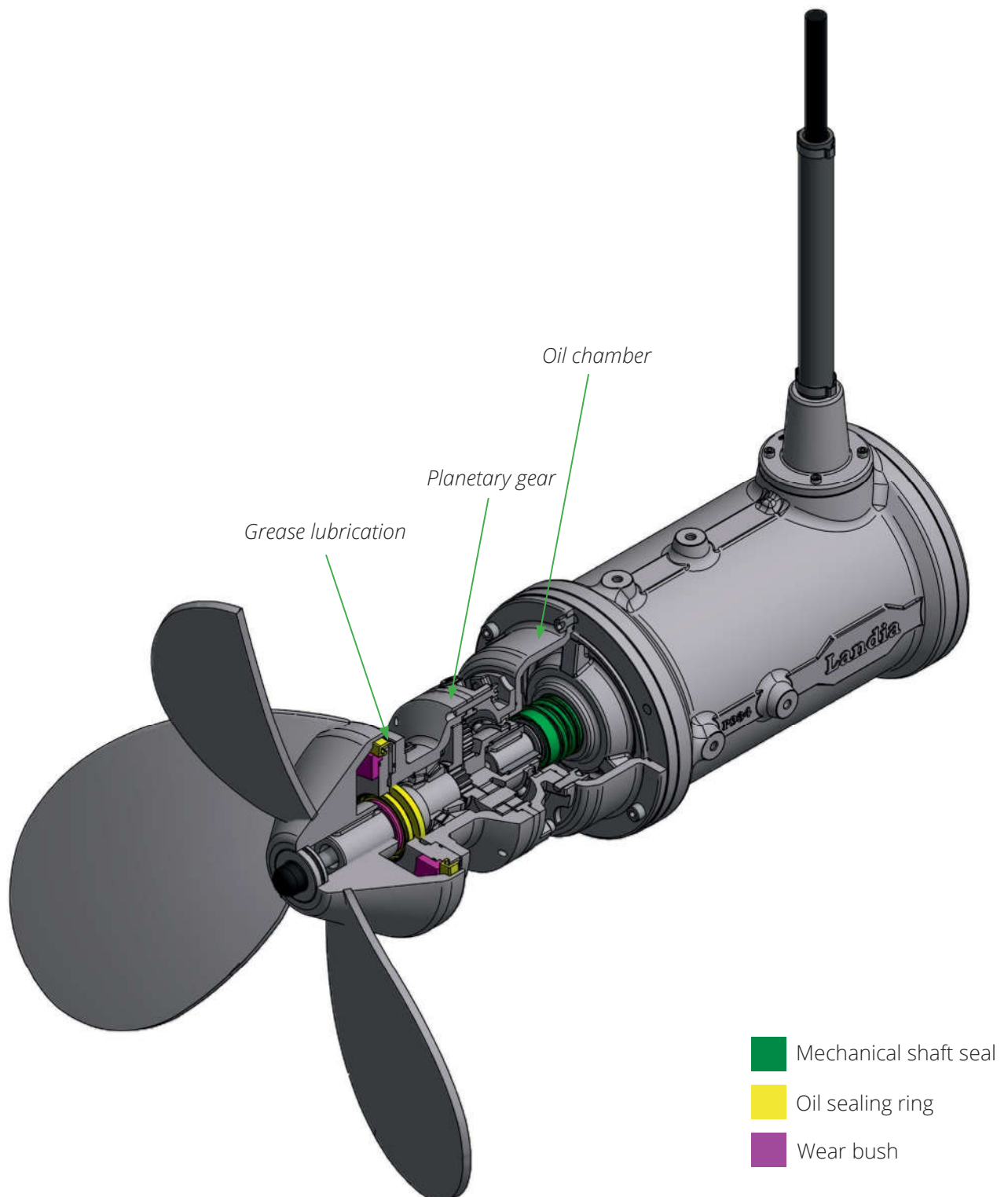

## DESIGN POP-I 300/400 RPM

All Landia POP-I 300/400 mixers are delivered with a 1,500-rpm motor. A planetary gear box reduces the number of propeller revolutions to 300/400 and ensures a high propeller efficiency, resulting in powerful mixing.

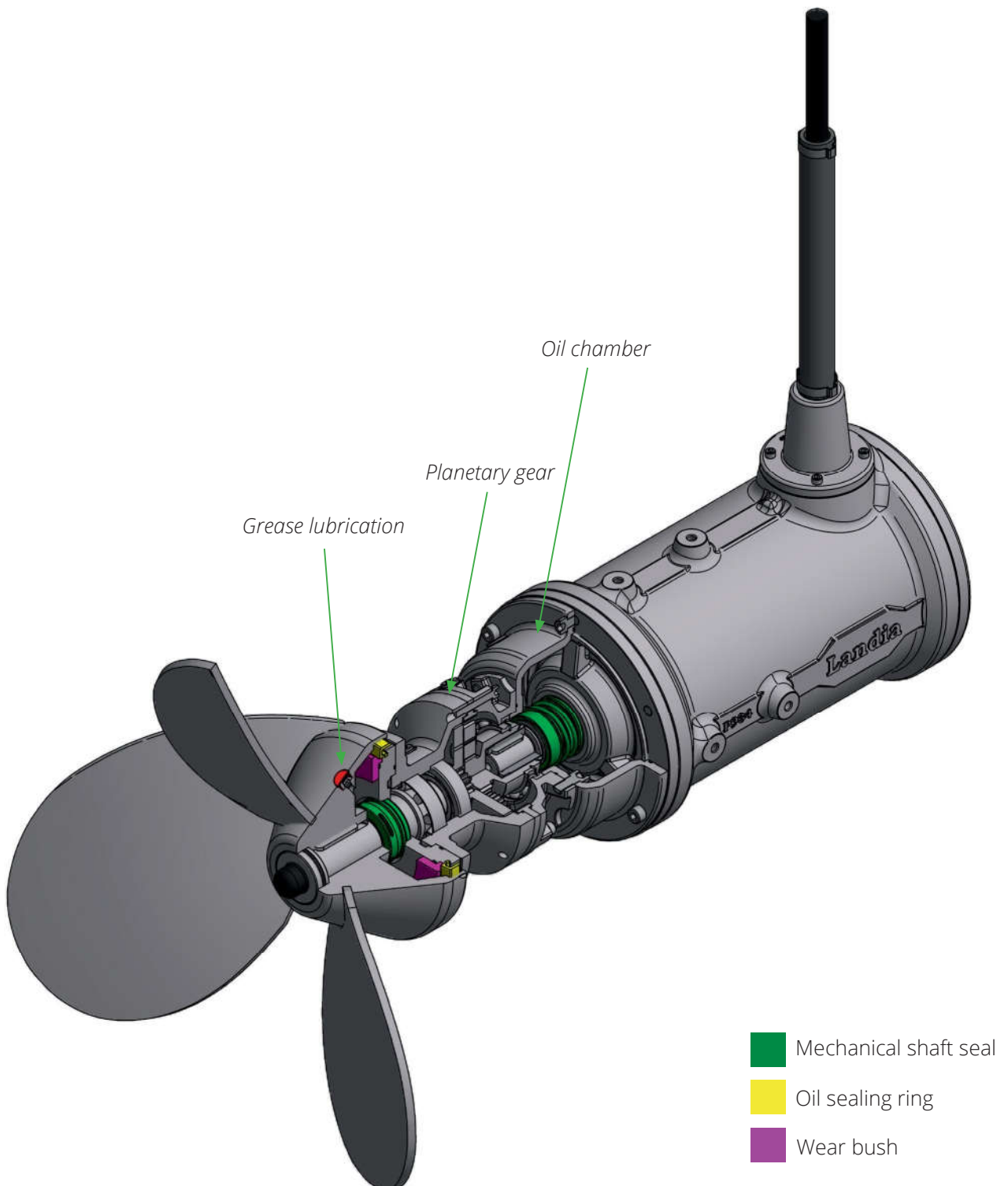



**ELECTRICAL DATA**

Motor type	3-phase AC motor
Nominal voltage	400 V
Minimum voltage allowed	360 V
Nominal frequency	50 Hz
Applicable for VFD operation	Yes
Ingress protection rating	IP 68
Insulation class	F
ATEX classification	II 2 G Ex db h IIB T4 Gb (Option, only available for specific models)

Model	Item number	Nominal power	Motor	Full load current (400 V)	Connection method	Start current (DOL)	cos phi	Efficiency
		[kW]	[rpm]	[A]	Y/Δ	[A]		[%]
POP-I 1.1/0.75 kW-150 rpm IE2	1136301	1.1	955	2.75	Y	15	0.71	78.1
POP-I 3.0/1.1 kW-150 rpm IE2	1136303	3.0	955	7.1	Δ	50	0.73	83.3
POP-I 4.0/3.0 kW-150 rpm IE2	1136304	4.0	965	8.5	Δ	43	0.79	85.5
POP-I 7.5/4.0 kW-150 rpm IE2	1136307	7.5	970	15.5	Δ	91	0.79	87.5
POP-I 1.1 kW-300 rpm	1114398	1.1	1,410	2.6	Y	14	0.79	76.7
POP-I 1.5 kW-300 rpm	1114301	1.5	1,400	3.4	Y	19	0.81	78.6
POP-I 2.2 kW-300 rpm	1114302	2.2	1,410	5.0	Y	30	0.80	80.2
POP-I 3.0 kW-300 rpm	1114303	3.0	1,430	6.7	Δ	43	0.79	82.4
POP-I 4.0 kW-300 rpm	1114304	4.0	1,435	8.8	Δ	61	0.78	84.1
POP-I 5.5 kW-300 rpm	1114305	5.5	1,440	11.0	Δ	68	0.87	84.6
POP-I 7.5 kW-300 rpm	1114307	7.5	1,455	15.0	Δ	90	0.83	86.2
POP-I 11.0 kW-300 rpm	1114311	11.0	1,455	21.5	Δ	146	0.84	87.9
POP-I 15.0 kW-300 rpm	1114315	15.0	1,465	29.0	Δ	212	0.84	88.7
POP-I 18.5 kW-300 rpm	1114318	18.5	1,460	35.0	Δ	238	0.85	89.3
POP-I 22.0 kW-400 rpm	1114324	22.0	1,465	43.0	Δ	280	0.82	90.1
POP-I 30.0 kW-400 rpm	1114332	30.0	1,465	57.0	Δ	399	0.84	90.7

For voltages others than 400 V/50 Hz please refer to the attached Appendix.

**ELECTRICAL DATA**

Motor type	3-phase AC motor
Nominal voltage	230 V
Minimum voltage allowed	207 V
Nominal frequency	50 Hz
Applicable for VFD operation	Yes
Ingress protection rating	IP 68
Insulation class	F
ATEX classification	Not possible

Model	Item number	Nominal power	Motor	Full load current (230 V)	Connection method	Start current (DOL)	cos phi	Efficiency
		[kW]	[rpm]	[A]	Y/Δ	[A]		[%]
POP-I 22.0 KW-400 rpm 3x230V	1114325	22.0	1,465	74.4	Δ	485	0.82	90.1
POP-I 30.0 KW-400 rpm 3x230V	1114333	30.0	1,465	98.7	Δ	691	0.84	90.7

## OVERALL DIMENSIONS

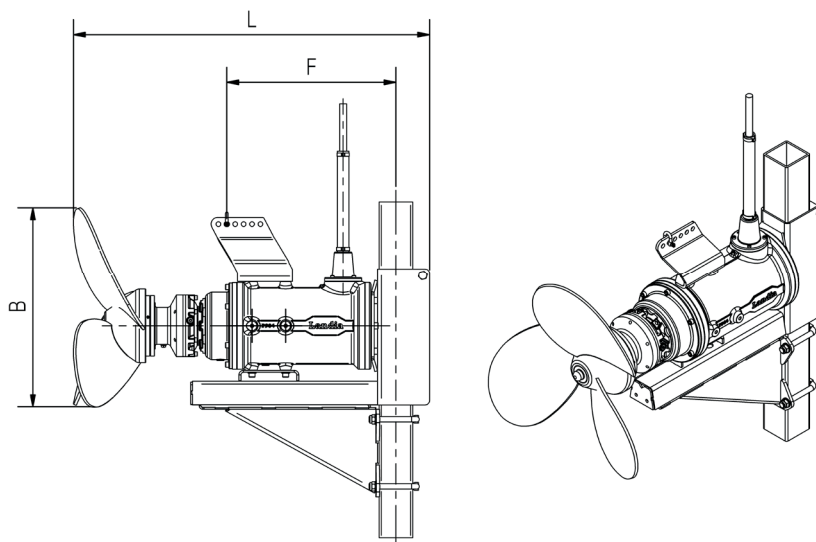

Model	Item number	Propeller diameter [mm]	B [mm]	F [mm]	L [mm]	Guide pipe [mm]	Weight [kg]
POP-I 1.1/0.75 kW-150 rpm IE2	1136301	ø620	510	400	890	80 × 80	112
POP-I 3.0/1.1 kW-150 rpm IE2	1136303	ø730	585	390	990	80 × 80	130
POP-I 3.0/11 kW-150 rpm IE2	1136303	ø845	685	390	990	80 × 80	130
POP-I 3.0/1.1 kW-150 rpm IE2	1136303	ø900	735	390	990	80 × 80	130
POP-I 4.0/3.0 kW-150 rpm IE2	1136304	ø930	770	495	1,110	100 × 100	180
POP-I 7.5/4.0 kW-150 rpm IE2	1136307	ø1030	835	530	1,270	100 × 100	250
POP-I 7.5/4.0 kW-150 rpm IE2	1136307	ø1150	980	530	1270	100 × 100	250
POP-I 1.1 kW-300 rpm	1114398	ø365	310	330	765	80 × 80	69
POP-I 1.5 kW-300 rpm	1114301	ø410	345	320	765	80 × 80	71
POP-I 2.2 kW-300 rpm	1114302	ø450	375	345	765	80 × 80	74
POP-I 3.0 kW-300 rpm	1114303	ø490	465	390	865	80 × 80	95
POP-I 4.0 kW-300 rpm	1114304	ø575	470	380	885	80 × 80	99
POP-I 5.5 kW-300 rpm	1114305	ø620	510	425	952	80 × 80	112
POP-I 7.5 kW-300 rpm	1114307	ø660	555	450	1,067	100 × 100	152
POP-I 11.0 kW-300 rpm	1114311	ø770	650	475	1,095	100 × 100	194
POP-I 15.0 kW-300 rpm	1114315	ø840	690	490	1,140	100 × 100	235
POP-I 18.5 kW-300 rpm	1114318	ø880	730	485	1,170	100 × 100	242
POP-I 22.0 kW-400 rpm	1114324	ø770	710	550	1,265	100 × 100 *	281
POP-I 30.0 kW-400 rpm	1114332	ø770	710	550	1,265	100 × 100 *	297
POP-I 22.0 kW-400 rpm 3x230V	1114325	ø770	710	550	1,265	100 × 100 *	281
POP-I 30.0 kW-400 rpm 3x230V	1114333	ø770	710	550	1,265	100 × 100 *	297

\*200x100 stainless guide pipe

We reserve the right to make technical changes.

landia.world.com

Prepared by: BNV/GB  
Approved by: KSK/TM

**Landia**<sup>®</sup>

Issued on: 1 January 2018  
Rev. date: 20. May 2021

# POPR-I

Landia POPR-I mixers are made from stainless steel. The POPR-I mixers are available with a propeller speed of 150, 300 or 400 rpm, with motor sizes ranging from 1.1 to 30.0 kW. They are also available in Super Duplex (SAF 2507), which is 100% resistant to sea water.

## APPLICATION EXAMPLES

- ▶ Acidic liquids
- ▶ Liquids with a high chloride content, such as at desalination plants
- ▶ Anoxic and anaerobic tanks
- ▶ SBR reactors
- ▶ Sludge tanks
- ▶ MBBR reactors
- ▶ Fishensilage

## PROPELLER RPM

150 rpm – gear 1:6 or 1:7.25

300 rpm – gear 1:4.5 or 1:5

400 rpm – gear 1:3.55



**MATERIAL OF CONSTRUCTION POPR-I 150 RPM**

Motor housing and oil chamber	W1.4404/AISI316
Propeller	Stainless steel W1.4301/AISI304 W1.4404/AISI316 (optional)
Protection jacket over gear box	Acid-proof steel W1.4404
Gear	Cast iron EN-GJL-250 (no contact with the liquid)
Gear output shaft	Shaft steel W1.6511/9840 (no contact with the liquid)
Bolts	A4
Exterior sealing system	3 oil sealing rings made of nitrile Wear bush made of stainless steel W1.4301/AISI304 (ceramic coating optional) Wear bush made of steel W1.2363/A2
Interior sealing system	Mechanical shaft seal: silicon carbide/silicon carbide
Oil type	Liquid temperature 0–30 °C SP 100 Liquid temperature 30–60 °C GS 220 GS 220 (with moisture detection)
Grease type	High temperature grease

**MATERIAL OF CONSTRUCTION POPR-I 300/400 RPM**

Motor housing and oil chamber	W1.4408/AISI316
Propeller	Stainless steel W1.4301/AISI304 W1.4404/AISI316 (optional)
Protection jacket over gear box	W1.4404/AISI316
Gear	Cast iron EN-GJL-250 (no contact with the liquid)
Gear output shaft	Shaft steel W1.6511/9840 (no contact with the liquid)
Bolts	A4
Exterior sealing system	1 oil sealing ring made of nitrile Wear bush made of stainless steel W1.4301/AISI304 (ceramic coating optional) Mechanical shaft seal: silicon carbide/silicon carbide
Interior sealing system	Mechanical shaft seal: silicon carbide/silicon carbide
Oil type	Liquid temperature 0–30 °C SP 100 Liquid temperature 30–60 °C GS 220 GS 220 (with moisture detection)
Grease type	High temperature grease

## SERVICE AND MAINTENANCE

Recommended service interval/oil change	Maximum 4,300 operating hours/minimum once a year
Motor	Lifetime lubricated bearings
Gear	Periodic oil change Calculated service life >100,000 operating hours
Propeller	Periodic grease lubrication

## ELECTRICAL CABLE

H07RN-F/S07RN-F EUCAFLEX<sup>Plus</sup> Cable.

Resistant to oil and UV radiation.



Number of conductors:

H07RN-F 7G1.5 mm<sup>2</sup> (Not used in United Kingdom)

H07RN-F 7G2.5 mm<sup>2</sup> (Only United Kingdom. Motor ≤ 5,5 kW)

S07RN-F 7G4+3x1.5 mm<sup>2</sup>

S07RN-F 7G6+3x1.5 mm<sup>2</sup>

As standard supplied with 7 m of cable (extra length available upon request).

## MONITORING FUNCTIONS

Bimetal thermal sensors 120 °C

Moisture detection system (optional)

## DESIGN POPR-I 150 RPM

The Landia POPR-I 150 is delivered with a 1,000-rpm IE2 motor. A planetary gearbox reduces the number of propeller revolutions to 150, which gives a high propeller efficiency, resulting in low energy consumption.

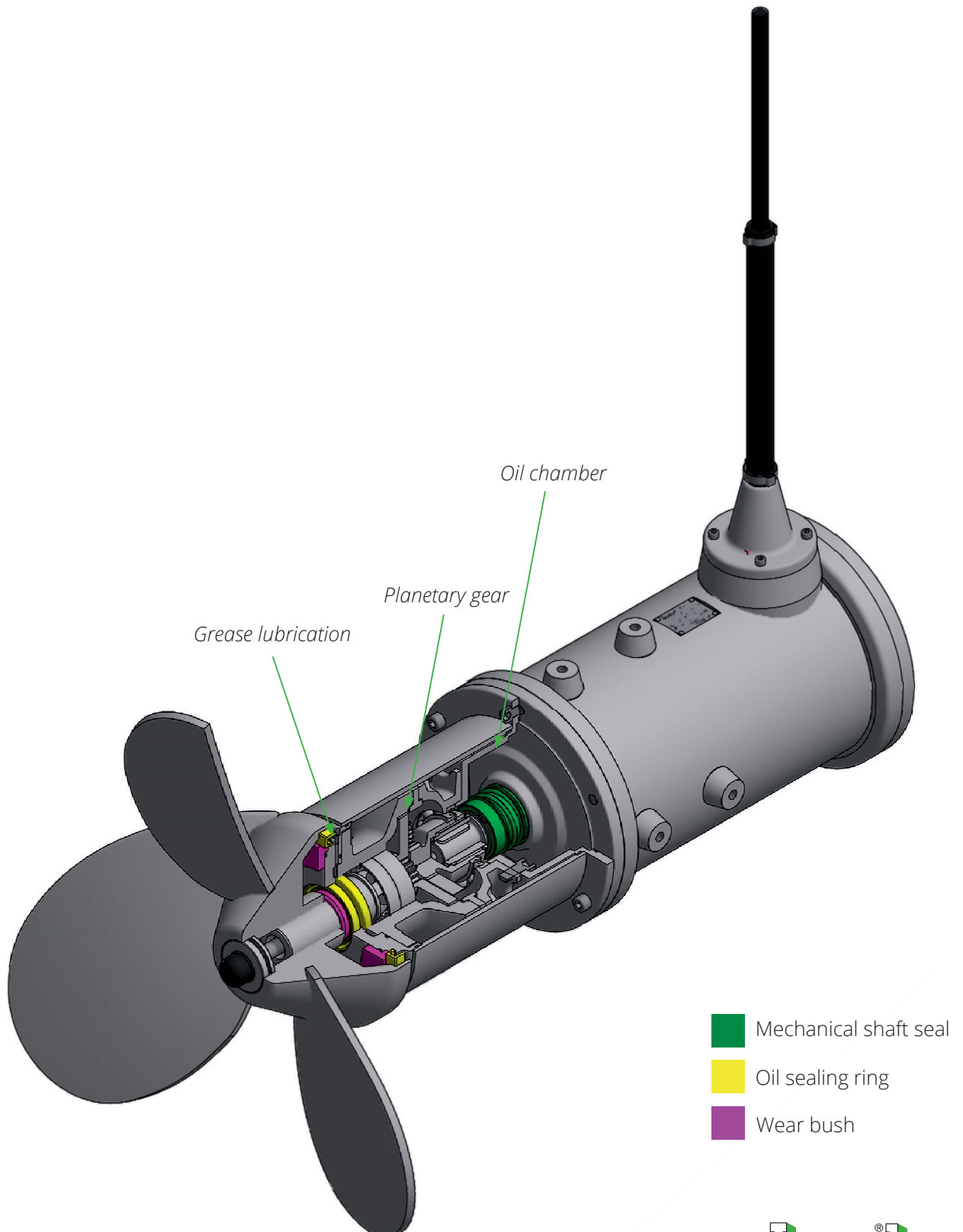



### DESIGN POPR-I 300/400 RPM

The Landia POPR-I 300/400 is delivered with a 1,500-rpm motor. A planetary gear box reduces the number of propeller revolutions to 300/400, and ensures a high propeller efficiency, resulting in powerful mixing.

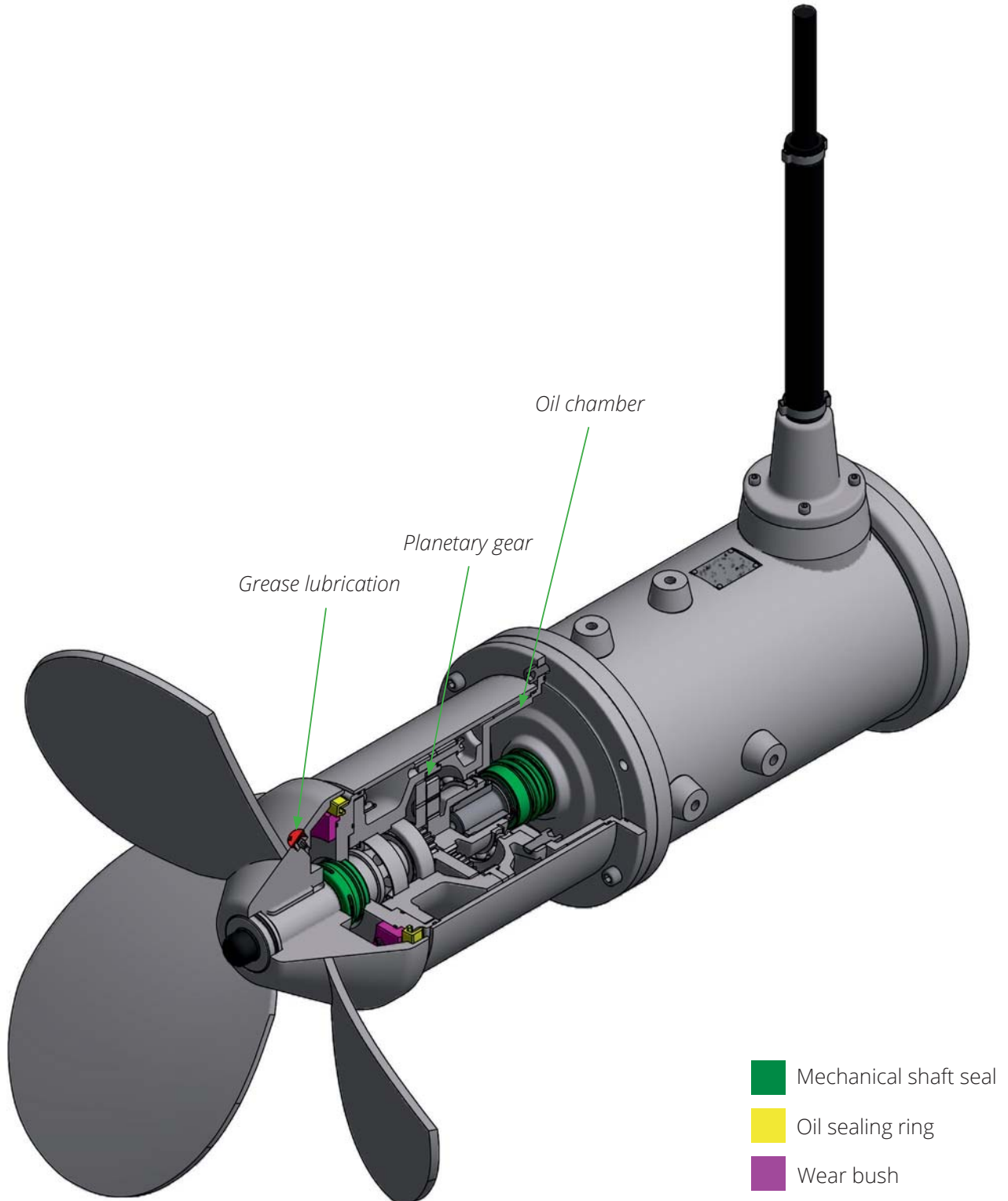

**ELECTRICAL DATA**

Motor type	3-phase AC motor
Nominal voltage	400 V
Minimum voltage allowed	360 V
Nominal frequency	50 Hz
Applicable for VFD operation	Yes
Ingress protection rating	IP 68
Insulation class	F
ATEX classification	Not possible

Model	Item number	Nominal power	Motor	Full load current (400 V)	Connection method	Start current (DOL)	cos phi	Efficiency
		[kW]	[rpm]	[A]	Y/Δ	[A]		[%]
POPR-I 1.1/0.75 kW-150 rpm IE2	1136201	1.1	955	2.75	Y	15	0.71	78.1
POPR-I 4.0/3.0 kW-150 rpm IE2	1136204	4.0	965	8.5	Δ	43	0.79	85.5
POPR-I 7.5/4.0 kW-150 rpm IE2	1136207	7.5	970	15.5	Δ	91	0.79	87.5
POPR-I 3.0 kW-300 rpm	1114203	3.0	1,430	6.7	Δ	43	0.79	82.4
POPR-I 4.0 kW-300 rpm	1114204	4.0	1,435	8.8	Δ	61	0.78	84.1
POPR-I 7.5 kW-300 rpm	1114207	7.5	1,455	15.0	Δ	90	0.83	86.2
POPR-I 11.0 kW-300 rpm	1114211	11.0	1,455	21.5	Δ	146	0.84	87.9
POPR-I 15.0 kW-300 rpm	1114215	15.0	1,465	29.0	Δ	212	0.84	88.7
POPR-I 18.5 kW-300 rpm	1114218	18.5	1,460	35.0	Δ	238	0.85	89.3
POPR-I 22.0 kW-400 rpm	1114223	22.0	1,465	43.0	Δ	280	0.82	90.1
POPR-I 30.0 kW-400 rpm	1114231	30.0	1,465	57.0	Δ	399	0.84	90.7

For voltages others than 400 V/50 Hz please refer to the attached Appendix.

## OVERALL DIMENSIONS

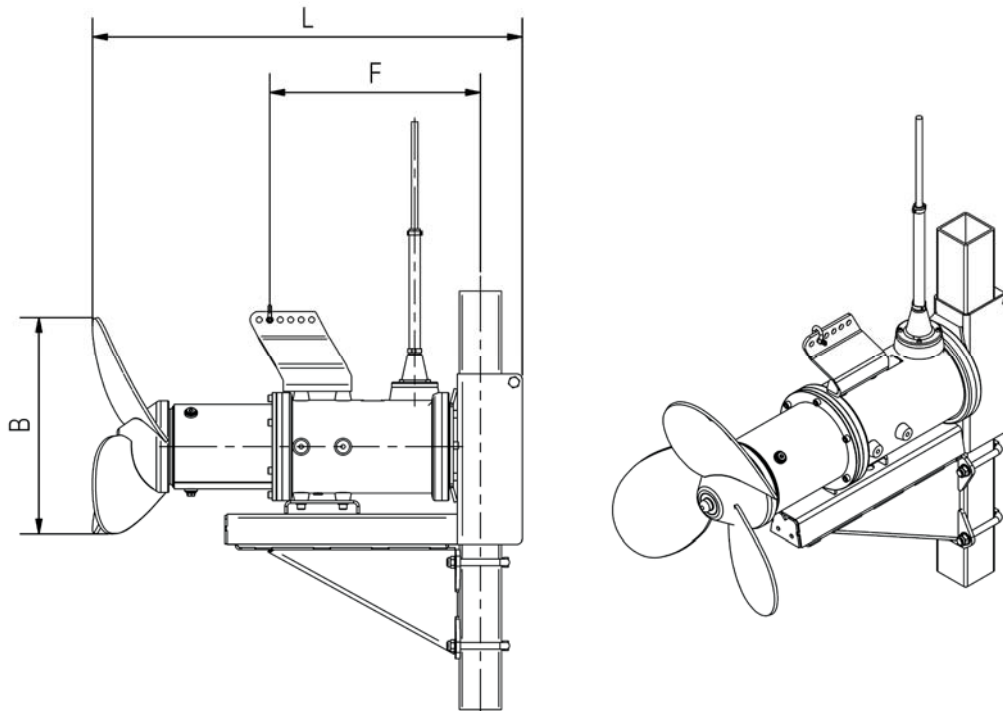

Model	Item number	Propeller diameter [mm]	B [mm]	F [mm]	L [mm]	Guide pipe [mm]	Weight [kg]
POPR-I 1.1/0.75 kW-150 rpm IE2	1136201	ø620	510	400	890	80 x 80	118
POPR-I 4.0/3.0 kW-150 rpm IE2	1136204	ø730	585	490	1,110	100 x 100	188
POPR-I 4.0/3.0 kW-150 rpm IE2	1136204	ø845	685	490	1,110	100 x 100	188
POPR-I 4.0/3.0 kW-150 rpm IE2	1136204	ø900	735	490	1,110	100 x 100	188
POPR-I 4.0/3.0 kW-150 rpm IE2	1136204	ø930	770	490	1,110	100 x 100	188
POPR-I 7.5/4.0 kW-150 rpm IE2	1136207	ø1030	835	530	1,220	100 x 100	259
POPR-I 7.5/4.0 kW-150 rpm IE2	1136207	ø1080	905	530	1,220	100 x 100	259
POPR-I 3.0 kW-300 rpm	1114203	ø490	465	390	865	80 x 80	113
POPR-I 4.0 kW-300 rpm	1114204	ø575	470	380	885	80 x 80	119
POPR-I 7.5 kW-300 rpm	1114207	ø660	555	450	1,067	100 x 100	164
POPR-I 11.0 kW-300 rpm	1114211	ø770	650	475	1,095	100 x 100	194
POPR-I 15.0 kW-300 rpm	1114215	ø840	690	490	1,140	100 x 100	235
POPR-I 18.5 kW-300 rpm	1114218	ø880	730	485	1,170	100 x 100	242
POPR-I 22.0 kW-400 rpm	1114223	ø770	710	550	1,265	100 x 100 *	281
POPR-I 30.0 kW-400 rpm	1114231	ø770	710	550	1,265	100 x 100 *	297

\*200x100 stainless guide pipe

We reserve the right to make technical changes.

## Table of contents

Introduction .....	2
Application.....	2
Warning.....	2
Note before commissioning .....	2
Service/repair .....	3
Rating plate .....	4
Power connection.....	4
Operation .....	5
Capacity .....	5
Inspection.....	5
Equipment .....	6
Disassembling/assembling .....	6

## Introduction

POP-I is a horizontal submersible mixer.

During operation, the mixer is locked by a conic stop console/stop bracket fixed to the guide pipe to obtain stability. The mixing takes place by means of an electric motor coupled to the propeller by means of a planetary gear. The oil filled coupling/oil chamber between motor and gear is in open connection with the gear, so the oil cools and lubricates the gear and the mechanical shaft seal between the oil chamber and the motor. The hub is installed on the propeller shaft, the output shaft of the gear. The exterior sealing system consists of three sealing rings with grease filled chambers between these.

The following pages describe the connection and the maintenance of mixers type POP-I.

## Application

This mixer is to be used for flow creation, mixing and homogenization of liquids with a high or low dry matter content, like e.g. wastewater, sludge, paper pulp, chemical liquids, and manure. The mixer can be placed in square and circular tanks and is to be applied only fully submerged below liquid level. If more than one mixer is installed in the tank, the horizontal setting between the mixers must not deviate more than a maximum of 5 ° from each other. If the mixer is to be applied for other purposes, contact Landia A/S for advice.

## Warning

Please note the following points:

- Only a certified electrician is allowed to connect the unit.
- Prior to installation and commissioning ensure that the equipment is installed correctly and fixed to the mixer, as well as ensure that the equipment in the tank is fixed safely.
- Prior to the first start of the mixer, the propeller shaft must be rotated manually. This also applies if the mixer has not been in operation for a longer period.
- The electrical cable is always to be tightened by means of the chain to prevent the cable from getting into contact with the propeller. If the mixer is not supplied with a chain, the cable is to be protected against damage in another way, e.g. by means of a cable mesh.
- It must be ensured that the propeller cannot touch the tank.
- It is always to be ensured that the mixer is fully below liquid level during operation.
- Prior to hoisting the mixer at service/repair, it is always to be ensured that the electrical connection of the mixer is switched off or locked. Prior to service/repair, the mixer should be cleaned thoroughly.
- When the mixer is hoisted or lowered, its cable and chain are always to be placed outside the work area.
- For service/repair of mixers installed in well/tank with explosion danger/toxic gases we refer to the national safety directions as far as safety is concerned, e.g. concerning the toxic hydrogen sulphide.

## Note before commissioning

If the machine has been installed in an empty tank for more than 1 month - and with a possible risk that the machine has been exposed to high temperatures or direct sun – the grease in the propeller hub and oil level in the oil chamber must be checked/refilled. If the machine has been in storage for more than 3 months, the shaft must be rotated manually before start-up to ensure lubrication of the sealing system.

**Service/repair**

To maintain a high operating safety and a long service life without unnecessary and expensive repair, it is important from the beginning to execute regular and preventive service. Maintenance should be executed according to the intervals stated in the manual. Always follow the instruction carefully and only apply the parts described by Landia A/S in the spare parts list. If you do not want to execute the service yourself - we can offer you a service agreement - please call for further information.

**Please note**

If spare parts not identical to the recommended are applied at service/repair, the guarantee from Landia A/S will be annulled. Spare parts can be ordered at Landia A/S or your local distributor.

For major repairs at a special workshop please contact:

Head Office:  
LANDIA A/S  
Industrivej 2  
DK-6940 Lem St.  
Tel.: +45 97 341244  
[info@landia.dk](mailto:info@landia.dk)  
[www.landia.dk](http://www.landia.dk)

UK subsidiary:  
Landia (UK) Ltd.  
Waymills Industrial Estate,  
Whitchurch,  
Shropshire SY13 1TT  
Tel: + 44 01948 661 200  
[info@landia.co.uk](mailto:info@landia.co.uk)  
[www.landia.co.uk](http://www.landia.co.uk)

Landia A/S is represented by local distributors worldwide, please call for further information.

## Rating plate

	DK-6940 Lem St.		
Type	3~mot.nr.		
	V		A
	Hz	kW	Ins.cl.
Cos φ	0,	RPM	kg
Eff. cl.	Year		
	IP 68	Duty type S1	

Type:	Unit type
3~mot.nr.:	Serial no.
V:	Connection voltage, star/delta
A:	Nominal power consumption at full load
Hz:	Net frequency
kW:	Max. shaft power
Ins.cl.:	Insulation class
Cos φ:	Power factor
RPM:	Motor revolutions per minute
Kg:	Weight of unit
Eff. cl.:	Efficiency class
Year:	Year of manufacture
IP:	Cage class
Duty type S1	Continuous working period

The rating plate states the motor's electrical data as well as the year of manufacture and the serial no. (3~Mot.nr.). With regard to maintenance of a specific unit please state serial no. when contacting Landia.

### Please note

It is important that the electrical cable is tightened to prevent the cable from getting into contact with the propeller. The cable can be ensured against damage by means of a cable mesh or a chain.

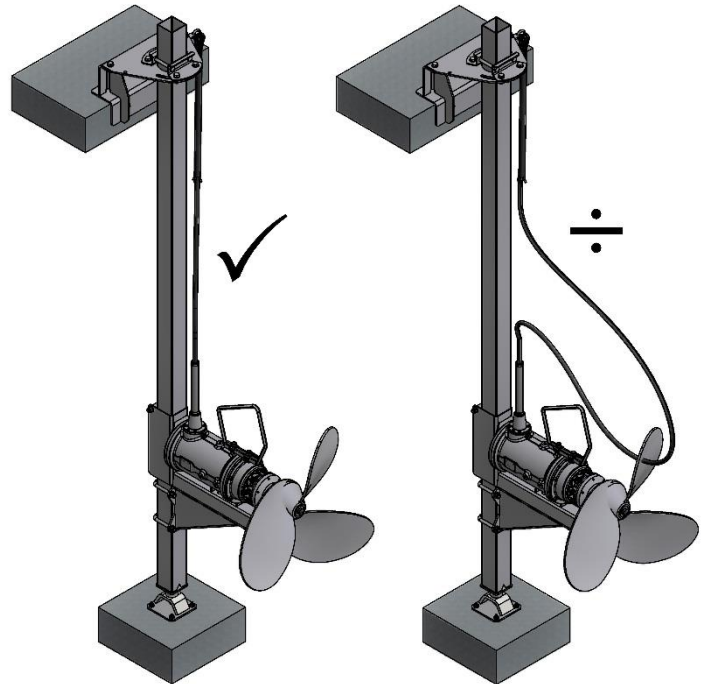

### Power connection

Every mixer is equipped with the above-mentioned rating plate with technical motor data. It must be ensured that the other electrical parts correspond to the motor data. For each mixer there is an electrical diagram. A protective motor switch must be applied at connection of the mixer to the mains.

### Softstarter and frequency converter

Improper motor connection and incorrectly connected/used softstarter or frequency converter can lead to faults in the machine's electric motor. Faults as a result are not covered by the machine's right of complaint.

**Only a certified electrician is allowed to connect the unit.**



## Operation

The mixers have thermal sensors as standard equipment. Often the mixers are exposed to extremely difficult operation conditions. Therefore, it is important to connect the thermal control. Burning of the motor due to overheating can thus be avoided. If the safety function has been activated the mixer must not be restarted until the cause of the disconnection has been found. Among other things the disconnection can be caused by reduced mains voltage, a propeller blockage or an overheated motor. The cooling period for overheated motors can be up to 1 hour.

**The unit must not operate above liquid level.**

## Capacity

The capacity of the mixer will always depend on the consistency of the medium, but especially on the design of the tank.

## Inspection

Regular inspection will ensure the mixer a long life at low costs. The oil must be changed every 6 months/4,300 hours of operation for POP-I 150 rpm and every 6 months/2000 operating hours for POP-I 300 rpm, however, min. once a year and under difficult operation conditions more often than every 6 months.

At inspection, the outer wear bush, pos. C, must be checked. There are two different kinds of the outer wear bush: a wear bush made of stainless steel and a type designed for extremely wearing mediums. This is a stainless-steel wear bush, covered with a ceramic material. The ceramic coated type is characterized by its dark colour on the wearing surface.

### With stainless steel wear bush

If the wear bush has deep wear traces, the propeller must be removed. A spacer, pos. H, can be installed between the interior wear bush, pos. D, and the propeller in order to move the wear area for the exterior oil sealing ring, pos. G. If it is impossible to move the wear area, either because it has been moved previously, or the wear area is too wide, a new wear bush must be installed.

### With ceramic coated wear bush

In this case, remove the propeller and check if the surface on the wear bush is mat/porous. If this is the case, the wear bush, pos. C, is worn and must be changed. It is very important to check the oil sealing ring, pos. G, for wear with this system.

When the propeller is removed, check the interior wear bush, pos. D, for wear traces. This wear bush can be turned once for a new wear area. The oil sealing rings, pos. F and G, (incl. of springs) must be checked for wear and changed if necessary.

- A. Grease chamber
- B. Grease nipple
- C. Outer wear bush
- D. Inner wear bush
- E. Grease chamber
- F. Oil seal rings
- G. Outer oil sealing ring
- H. Support disc

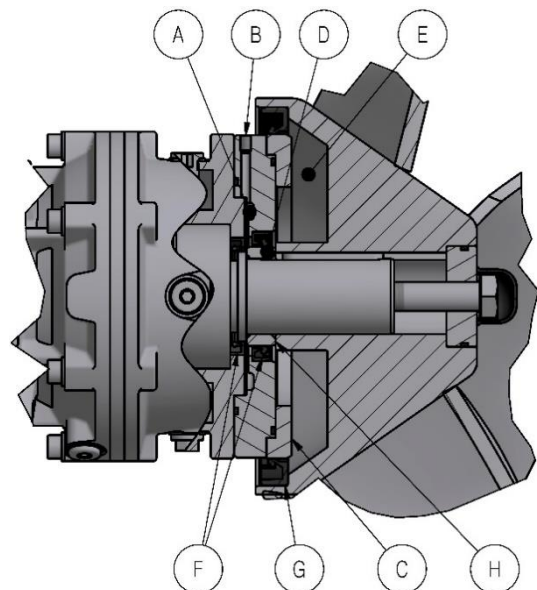

### Oil control

The oil is checked by removing the upper oil plug pos. A (ms.100-180) on the oil chamber or pos. G (ms.80-90) on the gear. The oil has to be clean and the level has to reach the plug hole. Oil type see table. If the oil is dirty it has to be exchanged.

- A. Upper oil plug, oil chamber
- B. Lower oil plug, oil chamber
- C. Lower oil plug, gear
- D. Inspection screw
- F. Stop screw/grease nipple
- G. Upper oil plug, gear

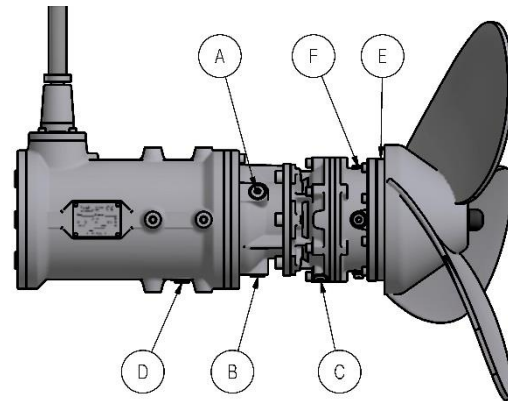

The oil is drained off by removing the plugs pos. B and pos. C (ms100-180) or pos. C (ms80-90). If the oil is dirty, seal and wear bushes must be checked for wear and contamination. During filling of oil through oil plug pos. A (ms100-180) the oil plug pos. G must be removed to allow bleeding of the gear. For ms80-90 oil is filled at oil plug pos. G on the gear.

Grease lubricates the outer sealing system (see spare part list). This takes place by removing the stop screw pos. F placed right behind the propeller hub and then lubricate through the grease nipple. For ms80 and ms90 the grease nipple is fixed. Prior to reinstallation the propeller fill up the hub with grease.

The motor casing must be checked in the following way: Remove the inspection plug pos. D beneath the motor. Any seepage of oil or liquid can be seen immediately. In case of abnormal seepage it is necessary to check the seal in the oil chamber. If it is necessary to dry up the motor windings, contact a special workshop.

### Equipment





The equipment should be checked for wear and corrosion. The winch is to be grease lubricated. Check brake and lock. Retighten screws. If the screws are loose remove them and lubricate with an adhesive substance (e.g. Loctite) prior to reinstallation.

### Disassembling/assembling

A major repair should take place at a special workshop.

Below please find some general conditions regarding disassembling/assembling of Landia mixer type POP-I. The drawing attached to the spare parts list shows the construction of the unit. Not all parts can/should be removed, e.g. do not press the rotor off the shaft.

When disassembling the unit, handle the mechanical seals with care as they are not shock resistant. Prior to reinstallation all sealing surfaces must be cleaned; all O-rings must be checked and changed if necessary. Adhesive substance (e.g. Loctite) must be applied on all bolt joints. All bolts are tightened with a tightening torque acc. to the table below.

Bolt sizes	Quality 10.9 – 12.9 Steel  	Quality A4-80 St. steel  
M6	14 Nm	10 Nm
M8	34 Nm	24 Nm
M10	67 Nm	48 Nm
M12	115 Nm	82 Nm
M16	160 Nm	137 Nm
M20	200 Nm	180 Nm
M30	620 Nm	620 Nm

**Note**

End cover, oil chamber and gear must be turned **anti-clockwise** as much as possible, seen from the end of the propeller, in order to balance the clearance in the bolt holes before the final tightening of the bolts. After installing the bearing flange, check the axial space; as stated in the table below.

Motor series	Acceptable margin
ms80	0.7 ± 0.05 mm
ms90	0.7 ± 0.05 mm
ms100	0.9 ± 0.05 mm
ms112	1.0 ± 0.05 mm
ms132	1.0 ± 0.05 mm
ms160	1.1 ± 0.05 mm
ms180	1.5 ± 0.05 mm

A. Bearing flange

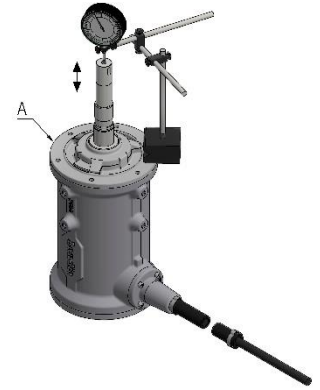

**Installation of mechanical shaft seals**

When installing the mechanical shaft seals please be aware that these are precision products and that they should be handled as such. The slide faces must be protected during the installation.

- B. Stationary sealing part
- C. Rotating sealing part
- D. Locking ring
- E. Shaft

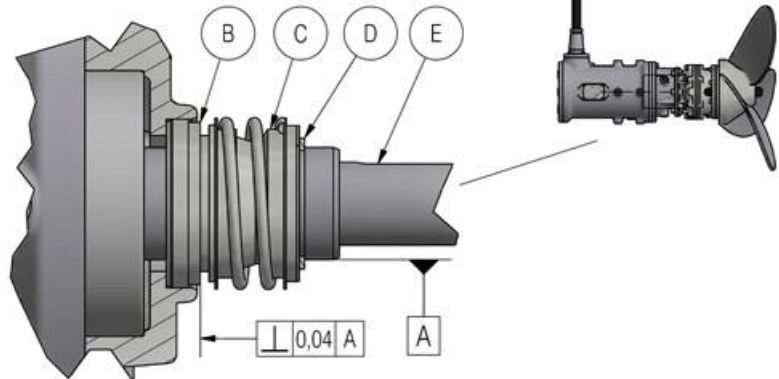

Push the stationary sealing part pos. B into place. Be careful not to damage the slide face during the installation.

When the stationary part is mounted and straightened with a dial gauge, wipe it off with degreaser.

The rotating sealing part pos. C is put over the shaft. To ease the installation put soap water on the interior side of the rubber bellows as well as on the shaft. Do not apply silicone, PTFE lubricants or oil as they will prevent the rubber bellows from sticking to the shaft. Installation arbor should be used.

Put the locking ring pos. D on the shaft and press together the seal until the locking ring snaps into the locking ring trace. Check the sealing by turning the motor shaft.

Test the mixer for leakage by submerging it and by putting the motor casing and the oil chamber under an overpressure. The overpressure is to be approx. 1 bar. Leakage (air bubbles) must not appear. Oil is filled into the oil chamber/gear. During the filling, the mixer must be in a horizontal position. Oil quantity: see Spare parts list.

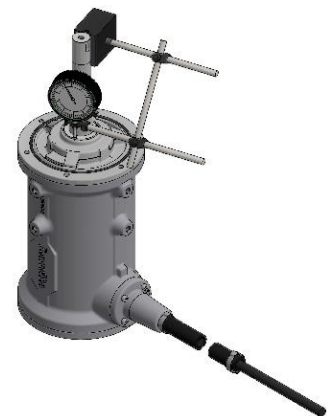

Repair of surface coating, if any, is necessary prior to operation start. See instruction for maintenance of surface coating.

We reserve the right to technical alterations. Translated from Danish.

## Table of contents

Introduction .....	2
Application.....	2
Warning.....	2
Note before commissioning .....	2
Service/repair .....	3
Rating plate .....	4
Power Connection.....	4
Operation .....	5
Capacity .....	5
Inspection.....	5
Equipment .....	6
Disassembling/assembling .....	6

## Introduction

POP-I is a horizontal submersible mixer.

During operation, the mixer is locked by a conic stop console/stop bracket fixed to the guide pipe. The mixing takes place by means of an electric motor coupled to the propeller by means of a planetary gear. The oil filled coupling/oil chamber between motor and gear is in an open connection with the gear, so the oil cools and lubricates the gear and the mechanical shaft seal between the oil chamber and the motor.

The propeller is installed on the output shaft of the gear. The exterior sealing system consists of an oil sealing ring and a mechanical shaft seal with a grease-filled chamber in between.

The following pages describe the connection and the maintenance of mixers type POP-I.

## Application

This mixer is to be used for flow creation, mixing and homogenization of liquids with high or low dry matter content, like e.g. wastewater, sludge, and paper pulp, as well as chemical liquids and manure. The mixer can be placed in square and circular tanks and may only operate when fully submerged below liquid level. When the mixer is in operation, it must be fixated to the stop console, which is installed on the guide pipe. If the guide pipe is without stop console, the mixer is suspended in the wire and is stopped by a stop bracket that is installed on the guide pipe.

If more than one mixer is installed in the tank, the horizontal setting between the mixers must not deviate more than a maximum of 5 ° from each other. If the mixer is to be applied for other purposes, contact Landia A/S for advice.

## Warning

Please note the following:

- Only a certified electrician is allowed to connect the unit.
- Prior to installation and start-up, check that the equipment is installed correctly to the mixer, as well as the equipment in the tank.
- Prior to the first start of the mixer, the propeller shaft must be rotated manually. This also applies if the mixer has not been in operation for a longer period.
- The electrical cable is always to be ensured by means of the chain to prevent the cable from getting into contact with the propeller. If the mixer is not supplied with a chain, the cable is to be protected against damage in another way, e.g. by means of a cable mesh.
- It must be verified that the propeller cannot touch the tank under any circumstances.
- The mixer must always be fully below liquid level during operation.
- Prior to hoisting the mixer for service/repair it is imperative that the electrical connection of the mixer is switched off or locked. Prior to service/repair the mixer should be cleaned thoroughly.
- When the mixer is hoisted or lowered, its cable and chain are always to be placed outside the work area.
- For service/repair of mixers installed in well/tank with explosion danger/toxic gases we refer to the national safety directions as far as safety is concerned, e.g. concerning the toxic hydrogen sulphide.

## Note before commissioning

If the machine has been installed in an empty tank for more than 1 month - and with a possible risk that the machine has been exposed to high temperatures or direct sun – the grease in the propeller hub and oil level in the oil chamber must be checked/refilled. If the machine has been in storage for more than 3 months, the shaft must be rotated manually before start-up to ensure lubrication of the sealing system.

**Service/repair**

To maintain a high operating safety and a long service life without unnecessary and expensive repair it is important from the beginning to execute regular and preventive service. Maintenance should be executed according to the intervals stated in the manual. Always follow the instructions carefully and only apply the parts described by Landia A/S in the spare parts list.

Landia A/S can refer you to a service partner in your area.

**Please note**

If spare parts not identical to the ones recommended are used at service/repair, the guarantee from Landia A/S will be voided. Spare parts can be ordered at Landia A/S or your local distributor.

For major repairs at a special workshop please contact:

Head Office:  
LANDIA A/S  
Industrivej 2  
DK-6940 Lem St.  
Tel.: +45 97 341244  
[info@landia.dk](mailto:info@landia.dk)  
[www.landia.dk](http://www.landia.dk)

UK subsidiary:  
Landia (UK) Ltd.  
Waymills Industrial Estate,  
Whitchurch,  
Shropshire SY13 1TT  
Tel: + 44 01948 661 200  
[info@landia.co.uk](mailto:info@landia.co.uk)  
[www.landia.co.uk](http://www.landia.co.uk)

Landia A/S is represented by local distributors worldwide, please call for further information.

## Rating plate

		DK-6940	CE	UK
		Lem St.	CA	
Type	<input type="text"/>	3~mot.nr.	<input type="text"/>	
	<input type="text"/>	V	<input type="text"/>	A
	<input type="text"/>	Hz	<input type="text"/>	kW
	<input type="text"/>	Ins.cl.	<input type="text"/>	
Cos φ	0, <input type="text"/>	RPM	<input type="text"/>	kg
Eff. cl.	<input type="text"/>	Year	<input type="text"/>	
	IP <input type="text"/>	Duty type	S1	

Type:	Unit type
3~mot.nr.:	Serial no.
V:	Connection voltage, star/delta
A:	Nominal power consumption at full load
Hz:	Net frequency
kW:	Max. shaft power
Ins.cl.:	Insulation class
Cos φ:	Power factor
RPM:	Motor revolutions per minute
Kg:	Weight of unit
Eff. cl.:	Efficiency class
Year:	Year of manufacture
IP:	Cage class
Duty type S1	Continuous working period

The rating plate states the motor's electrical data as well as the year of manufacture and the serial no. (3~Mot.nr.). With regard to maintenance of a specific unit please state serial no. when contacting Landia.

### Please note

It is important that the electrical cable is tightened to prevent the cable from getting into contact with the propeller. The cable can be ensured against damage by means of a cable mesh or a chain.

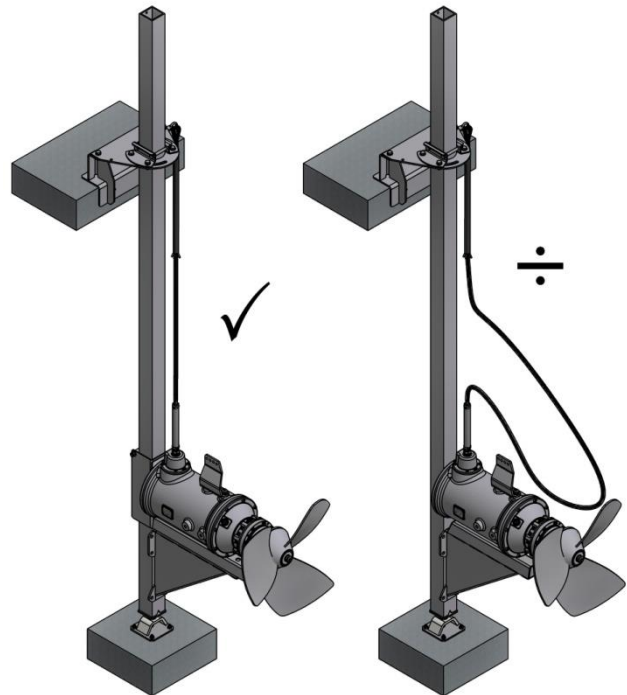

## Power Connection

Every mixer is equipped with the above mentioned rating plate with technical motor data. It must be verified that the other electrical parts correspond to the motor data. For each mixer there is an electrical diagram. A protective motor switch must be applied at connection of the mixer to the mains.

### Softstarter and frequency converter

Improper motor connection and incorrectly connected/used softstarter or frequency converter can lead to faults in the machine's electric motor. Faults as a result are not covered by the machine's right of complaint.

**Only a certified electrician is allowed to connect the unit.**



## Operation

The mixers have thermal sensors as standard equipment. Often the mixers are exposed to extremely difficult operation conditions. Therefore, it is important to connect the thermal control. Burning of the motor due to overheating can thus be avoided. If the safety function has been activated the mixer must not be re-started until the cause of the circuit disconnect has been determined. Among other things the disconnection can be caused by low mains voltage, a propeller blockage, or an overheated motor. The cooling period for overheated motors can be up to 1 hour.

**The unit must not operate above liquid level.**

## Capacity

The capacity of the mixer will always depend on the consistency of the medium, but especially on the design of the tank.

## Inspection

Regular inspection will ensure the mixer a long life at low costs. The oil must be changed every 6 months/4,300 hours of operation, however, min. once a year. Under difficult operation conditions, it must be changed more often than every 6 months. At inspection, the outer wear bushing must be checked for wear and replaced, if needed. There are two different kinds of the outer wear bushing: a wear bushing made of stainless steel and a type designed for extremely wearing mediums. This is a stainless steel wear bushing covered with a ceramic material. The ceramic coated type is characterized by its dark colour on the wearing surface.

### With stainless steel wear bushing

If the wear bushing has deep wear traces, the propeller must be removed. A spacer can be installed between the mechanical shaft seal and the propeller in order to move the wear area for the exterior oil sealing ring. If it is impossible to move the wear area, either because it has been moved previously, or the wear area is too wide, a new wear bushing must be installed.

### With ceramic coated wear bushing

Remove the propeller and control if the surface is mat/ porous. If this is the case the wear bushing is worn and must be changed. It is very important to control the oil sealing ring for wear with this system. The oil sealing ring (incl. of springs) must be checked for wear and changed, if necessary.

### Mechanical shaft seal

Remove the propeller and make a visual control of the outer mechanical shaft seal. Remove rags, if any, and in case the oil is dirty, remove the seal and control it for wear.

- A. Mechanical shaft seal
- B. Oil sealing ring
- C. Wear bush
- D. Grease chamber
- E. Grease nipple
- F. Support disc (not shown)

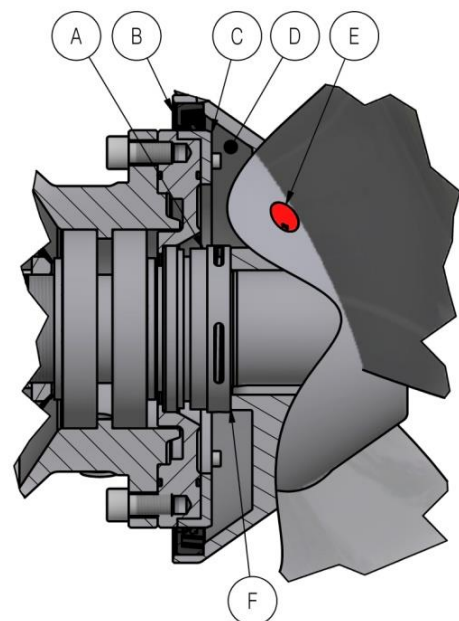

**Oil control**

The oil level is to be checked by removing the upper oil plug pos. A (ms.100-180) on the oil chamber or pos. G (ms.80-90) on the gear. The oil has to be clean and the level has to reach the plug hole. Oil type; see the spare parts list. If the oil is dirty it has to be changed.

- A. Upper oil plug, oil chamber
- B. Lower oil plug, oil chamber
- C. Lower oil plug, gear
- D. Inspection screw
- E. Top oil plug, gear
- F. Grease nipple

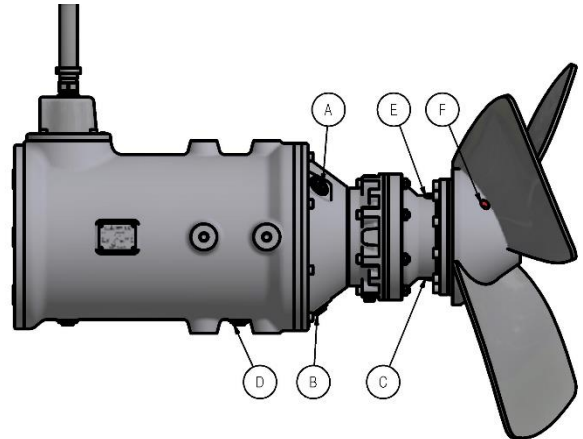

The oil is drained off by removing the plugs, pos. B and pos. C (ms.100-180) or pos. C (ms. 80-90). In case of contaminated oil, the seals and wear bushes must be checked for wear and contamination.

When filling oil through the oil plug, pos. A (ms.100-180), the oil plug (pos. E) must be removed to allow the venting of the gear unit. For ms.80-90, oil is filled through the oil plug (pos. G) on the gear.

Lubricate the outer sealing system with grease (see spare parts list). This takes place through the grease nipple, pos. F, which is fixed in the propeller behind one of the propeller blades. Prior to reinstalling the propeller fill up the hub with grease lubricant.

The motor casing must be inspected in the following way: Remove the inspection plug, pos. D, beneath the motor. Any leak of oil or liquid can be seen immediately.

In case of irregular leakage, it is necessary to check the seal in the oil chamber. If in doubt, please contact Landia. If it is necessary to dry up the motor windings, contact an electric motor repair workshop.

**Equipment**

The equipment should be inspected for wear and corrosion. The winch is to be lubricated with grease. Inspect brake and lock. Retighten screws. If the screws are loose, remove them and lubricate with Loctite 243 prior to reinstallation.

**Disassembling/assembling**

A major repair should take place at a workshop which is specialized in this type of repair. We can refer to a service partner in your territory. Below please find some general conditions regarding disassembling/ assembling of Landia mixer type POP-I. The drawing attached to the spare parts list shows the construction of the unit. Not all parts can/should be removed, e.g. do not press the rotor off the shaft.

When disassembling the unit, handle the mechanical seals with care as they are not shock resistant. Prior to reinstallation, all sealing surfaces must be cleaned; all O-rings must be checked and changed if necessary. Adhesive substance (e.g. Loctite) must be applied on all bolt joints. All bolts must be tightened with a torque wrench as specified in the table below.

Bolt sizes	Quality 10.9 – 12.9 Steel	Quality A4 kl. 80 St. steel
M6	14 Nm	10 Nm
M8	34 Nm	24 Nm
M10	67 Nm	48 Nm
M12	115 Nm	82 Nm
M16	160 Nm	137 Nm
M20	200 Nm	180 Nm

**Please Note**

End cover, oil chamber and gear must be turned **anti-clockwise** as much as possible, seen from the end of the propeller, in order to balance the space in the bolt holes before the final tightening of the bolts.  
After installing the bearing flange control the axial space as stated in the table below.

Motor series (ms.)	Acceptable margin
ms80	0.7 ± 0.05 mm
ms90	0.7 ± 0.05 mm
ms100	0.9 ± 0.05 mm
ms112	1.0 ± 0.05 mm
ms132	1.0 ± 0.05 mm
ms160	1.1 ± 0.05 mm
ms180	1.5 ± 0.05 mm

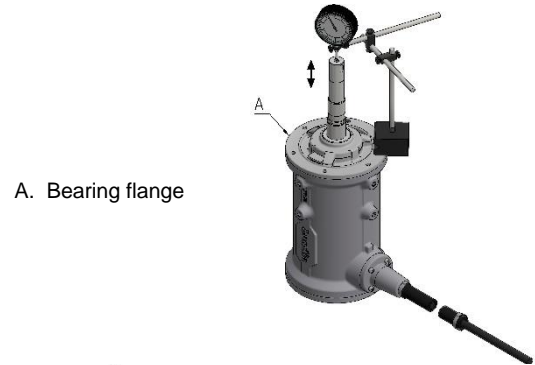

**Installation of mechanical shaft seals**

When installing the mechanical shaft seals, please be aware that these are precision products and that they should be handled as such. The slide faces must be protected during the installation.  
Push the stationary sealing ring into place. Be careful not to damage the slide face during the installation.

- B. Stationary sealing part
- C. Rotating sealing part
- D. Locking ring
- E. Shaft
- F. Propeller hub

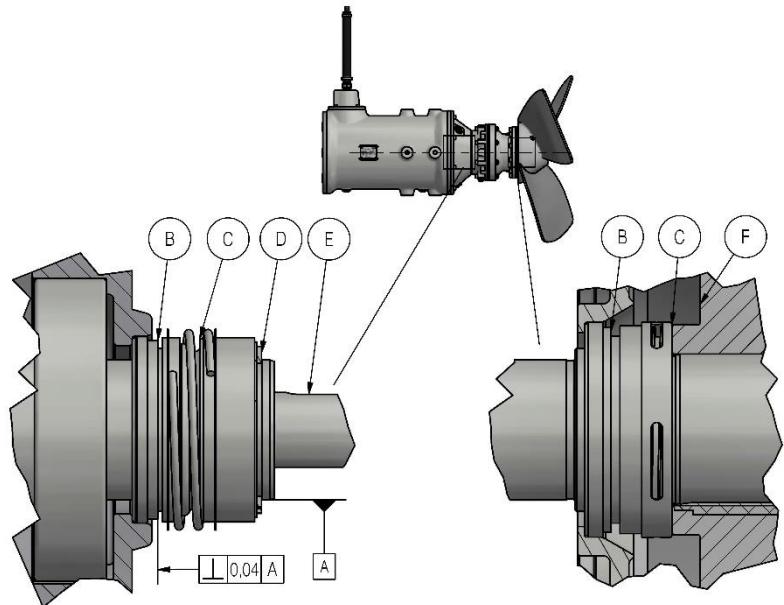

Push the stationary sealing part, pos. B, into place. Be careful not to damage the slide face during the installation.  
When the stationary part is mounted and straightened with a dial gauge, wipe it off with degreaser.

The rotating sealing ring is put over the shaft. To ease the installation put soap water on the interior side of the rubber bellows as well as on the shaft. Do not apply silicone, PTFE lubricants or oil as they will prevent the rubber bellows from sticking to the shaft. Installation arbour should be used.

The propeller hub keeps the outer mechanical shaft seal in place. This happens when the propeller hub is tightened against the output shaft collar. At the inner mechanical shaft seal the locking ring must be put on the shaft and the seal pressed together until the locking ring snaps into the locking ring groove. Inspect the sealing by turning the motor shaft.

Test the mixer for leakage by submerging it and by putting the motor casing and the oil chamber under pressure. The pressure is to be approx. 1 bar. Leakage (air bubbles) must not appear. Oil is filled into the oil chamber/gear. During the filling, the mixer must be in a horizontal position.  
Oil quantity: see spare parts list.

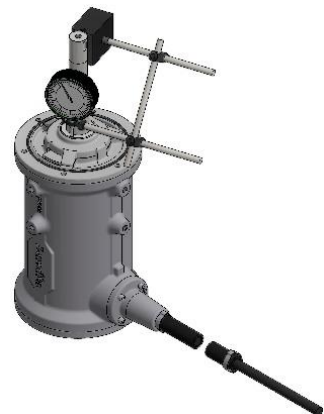

Repair of surface coating, if any, is necessary prior to operation start. See instruction for maintenance of surface coating.

We reserve the right to technical alterations Translated from Danish.

## Table og contents

Introduction .....	2
Application.....	2
Warning.....	2
Note before commissioning .....	2
Service/repair .....	3
Rating plate .....	4
Power connection.....	4
Operation .....	5
Capacity .....	5
Inspection.....	5
Equipment .....	6
Disassembling/assembling .....	6

## Introduction

POPR-I is a horizontal submersible mixer. All surfaces which are in contact with the medium are made of stainless steel.

During operation, the mixer is locked by a conic stop console/stop bracket fixed to the guide pipe to obtain stability. The mixing takes place by means of an electric motor coupled to the propeller by means of a planetary gear. The oil filled coupling/oil chamber between motor and gear is in open connection with the gear, so the oil cools and lubricates the gear and the mechanical seal between the oil chamber and the motor.

The hub is installed on the propeller shaft, the output shaft of the gear. The exterior sealing system consists of three sealing rings with grease filled chambers between these.

The following pages describe the connection and the maintenance of mixers type POPR-I.

## Application

This mixer is to be used for flow creation, mixing and homogenization of liquids with a high or low dry matter content, like e.g. wastewater, sludge, paper pulp as well as chemical liquids.

The mixer can be placed in square and circular tanks and is to be applied only fully submerged below liquid level.

If more than one mixer is installed in the tank, the horizontal setting between the mixers must not differ by more than a maximum of 5 ° from each other. If the mixer is to be applied for other purposes, contact Landia A/S for advice.

## Warning

Please note the following points:

- Only a certified electrician is allowed to connect the unit.
- Prior to installation and commissioning, ensure that the equipment is installed correctly and fixed to the mixer, as well as ensure that the equipment in the tank is fixed safely.
- Prior to the first start of the mixer, the propeller shaft must be rotated manually. This also applies if the mixer has not been in operation for a longer period.
- The electrical cable is always to be tightened by means of the chain to prevent the cable from getting into contact with the propeller. If the mixer is not supplied with a chain, the cable is to be protected against damage in another way, e.g. by means of a cable mesh.
- It must be ensured that the propeller cannot touch the tank.
- It is always to be ensured that the mixer is fully below liquid level during operation.
- Prior to hoisting the mixer at service/repair, it is always to be ensured that the electrical connection of the mixer is switched off or locked. Prior to service, the mixer should be cleaned thoroughly.
- When the mixer is hoisted or lowered, its cable and chain are always to be placed outside the work area.
- For service/repair of mixers installed in well/tank with explosion danger/toxic gases, we refer to the national safety directions as far as safety is concerned, e.g. concerning the toxic hydrogen sulphide.

## Note before commissioning

If the machine has been installed in an empty tank for more than 1 month - and with a possible risk that the machine has been exposed to high temperatures or direct sun – the grease in the propeller hub and oil level in the oil chamber must be checked/refilled. If the machine has been in storage for more than 3 months, the shaft must be rotated manually before start-up to ensure lubrication of the sealing system.

**Service/repair**

To maintain a high operating safety and a long service life without unnecessary and expensive repair it is important from the beginning to execute regular and preventive service. Maintenance should be executed according to the intervals stated in the manual. Always follow the instructions carefully and only apply the parts described by Landia A/S in the spare parts list.

If you do not want to execute the service yourself, we can offer you a service agreement - please call for further information.

**Please note**

If spare parts not identical to the recommended are applied at service/repair, the guarantee from Landia A/S will be annulled. Spare parts can be ordered at Landia A/S or your local distributor.

For major repairs at a special workshop please contact:

Head Office:	UK subsidiary:
LANDIA A/S	Landia (UK) Ltd.
Industrivej 2	Waymills Industrial Estate,
DK-6940 Lem St.	Whitchurch,
Tel.: +45 97 341244	Shropshire SY13 1TT
<a href="mailto:info@landia.dk">info@landia.dk</a>	Tel: + 44 01948 661 200
<a href="http://www.landia.dk">www.landia.dk</a>	<a href="mailto:info@landia.co.uk">info@landia.co.uk</a>
	<a href="http://www.landia.co.uk">www.landia.co.uk</a>

Landia A/S is represented by local distributors worldwide, please call for further information.

## Rating plate

	DK-6940 Lem St.		
Type	3~mot.nr.		
	V		A
	Hz	kW	Ins.cl.
Cos φ	0,	RPM	kg
Eff. cl.	Year		
	IP 68	Duty type S1	

Type:	Unit type
3~mot.nr.:	Serial no.
V:	Connection voltage, star/delta
A:	Nominal power consumption at full load
Hz:	Net frequency
kW:	Max. shaft power
Ins.cl.:	Insulation class
Cos φ:	Power factor
RPM:	Motor revolutions per minute
Kg:	Weight of unit
Eff. cl.:	Efficiency class
Year:	Year of manufacture
IP:	Cage class
Duty type S1	Continuous working period

The rating plate states the motor's electrical data as well as the year of manufacture and the serial no. (3~Mot.nr.). With regard to maintenance of a specific unit please state serial no. when contacting Landia.

### Please note

It is important that the electrical cable is tightened to prevent the cable from getting into contact with the propeller. The cable can be ensured against damage by means of a cable mesh or a chain.

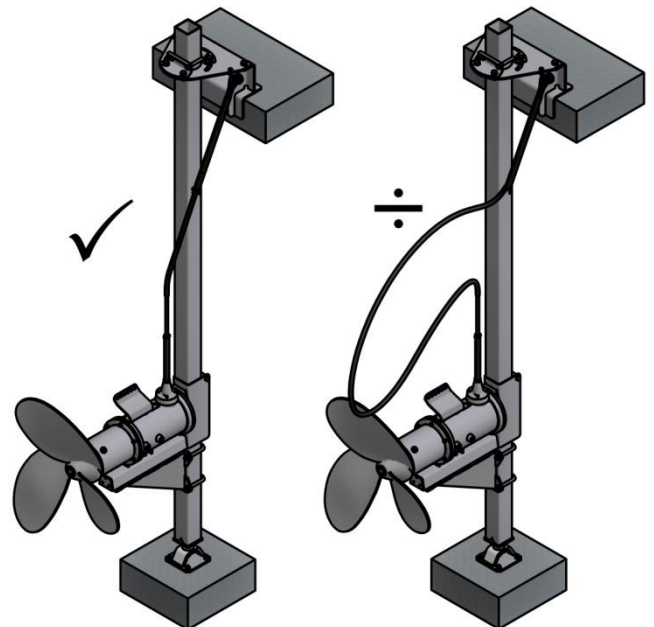

## Power connection

Every mixer is equipped with the above mentioned rating plate with technical motor data. It must be ensured that the other electrical parts correspond to the motor data. For each mixer there is an electrical diagram. A protective motor switch must be applied at connection of the mixer to the mains.

### Softstarter and frequency converter

Improper motor connection and incorrectly connected/used softstarter or frequency converter can lead to faults in the machine's electric motor. Faults as a result are not covered by the machine's right of complaint.

**Only a certified electrician is allowed to connect the unit.**



## Operation

The mixers have thermal sensors as standard equipment. Often the mixers are exposed to extremely difficult operation conditions. Therefore, it is important to connect the thermal control. Burning of the motor due to overheating can thus be avoided. If the safety function has been activated the mixer must not be re-started until the cause of the disconnection has been found. Among other things the disconnection can be caused by reduced mains voltage, a propeller blockage or an overheated motor. The cooling period for overheated motors can be up to 1 hour.

**The unit must not operate above liquid level.**

## Capacity

The capacity of the mixer will always depend on the consistency of the medium, but especially on the design of the tank.

## Inspection

Regular inspection will ensure the mixer a long life at low costs. Oil change must be done every 6 months/4300 operating hours for POPR-I 150 rpm and every 6 months/2000 operating hours for POPR-I 300 rpm, however, min. once a year. Under difficult operation conditions more often than every 6 months.

At inspection, the outer wear bush, pos. C, must be checked. There are two different kinds of outer wear bush: a wear bush made of stainless steel and a type designed for particularly abrasive media. This is a stainless steel wear bush, covered with a ceramic material. The ceramic coated type is characterized by its dark colour on the wearing surface.

### With stainless steel wear bush

If the wear bush has deep wear traces, the propeller must be removed.

A spacer, pos. H, can be installed between the interior wear bush, pos. D, and the propeller in order to move the wear area for the outer oil sealing ring, pos. G. If it is impossible to move the wear area, either because it has been moved previously, or the wear area is too wide, a new wear bush must be installed.

### With ceramic coated wear bush

In this case, remove the propeller and check if the wear bush is mat/porous. If this is the case, the wear bush, pos. C, is worn and must be changed. It is very important to check the oil sealing ring for wear with this system.

When the propeller is removed, check the inner wear bush, pos. D, for wear traces. This wear bush can be turned once for a new wear area. The oil sealing rings, pos. F and G, (incl. springs) must be inspected for wear and replaced if necessary.

- A. Grease chamber
- B. Grease nipple
- C. Outer wear bush
- D. Inner wear bush
- E. Grease chamber
- F. Oil sealing ring
- G. Utmost Oil sealing ring
- H. Spacer

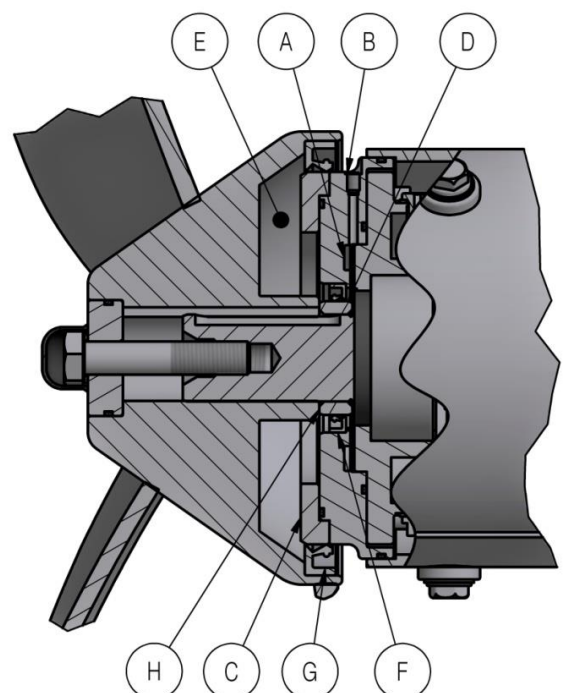



**Oil control**

The oil is controlled by removing the upper oil plug, pos. A. The oil has to be clean and the level has to reach the plug hole. Oil type: see spare parts list. If the oil is dirty it has to be exchanged.

- A. Upper oil plug
- B. Lower oil plug
- C. Stop screw / grease nipple
- D. Inspection screw

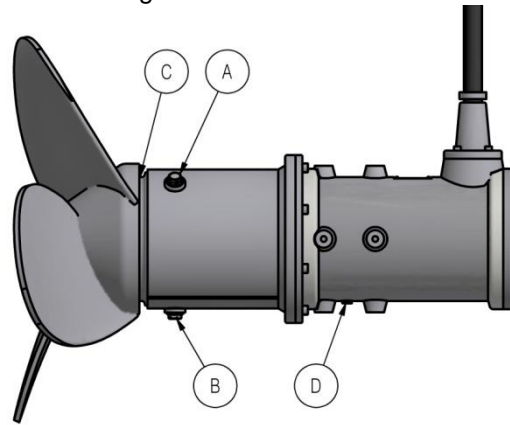

The oil is drained by removing the plug, pos. B. In case of contaminated oil, check the seals and wear bushings. Oil is filled by oil plug, pos. A.

Grease the front sealing system (see spare part list if necessary). Grease lubrication must be done by removing the stop screw, pos. C, which sits just behind the propeller hub; enclosed grease nipple is fitted, after which grease lubrication must take place through this. Before any reassembly of the propeller, fill the hub with grease.

The motor casing must be checked in the following way: Remove the inspection plug, pos. D beneath the motor. Any leakage of oil or liquid can be seen immediately.

In case of abnormal leakage, it is necessary to check the seal in the oil chamber. In case of doubt, Landia can be contacted. If it is necessary to dry up the motor windings, contact a special workshop.

**Equipment**

The equipment should be checked for wear and corrosion. The winch needs to be lubricated with grease. The brake and lock must be checked. Tightening of screws must be done. If the screws are loose, remove them and lubricate with an adhesive substance (e.g. Loctite) prior to reinstallation.

**Disassembling/assembling**

A major repair should take place at a special workshop.

Below please find some general conditions regarding disassembling/ assembling of Landia mixer type POPR-I.

The drawing attached to the spare parts list shows the construction of the unit. Not all parts can/should be removed, e.g. do not press the rotor off the shaft.

When disassembling the unit, handle the mechanical seals with care as they are not shock resistant.

Prior to reinstallation, all sealing surfaces must be cleaned; all O-rings must be checked and changed if necessary.

Adhesive substance (e.g. Loctite) must be applied on all bolt joints. All bolts are tightened with a tightening torque acc. to the table below.

Bolt sizes	Quality 10.9 - 12.9 Steel	Quality A4-80 Acidproof
M6	14 Nm	10 Nm
M8	34 Nm	24 Nm
M10	67 Nm	48 Nm
M12	115 Nm	82 Nm
M16	160 Nm	137 Nm
M20	200 Nm	180 Nm
M30	620 Nm	620 Nm

**Note**

End cover, oil chamber and gear must be turned **anti-clockwise** as much as possible, seen from the end of the propeller, in order to balance the clearance in the bolt holes before the final tightening of the bolts. After installing the bearing flange, the axial space must be controlled; as stated in the table below.

Motor series	Acceptable margin
ms100	0.9 ± 0.05 mm
ms132	1.2 ± 0.05 mm
ms160	1.2 ± 0.05 mm
ms180	1.8 ± 0.05 mm

A. Bearing flange

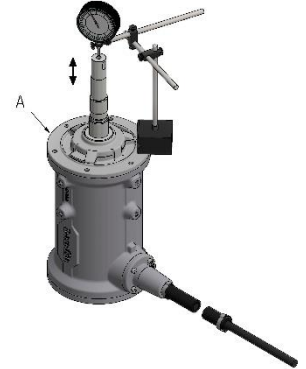

**Installation of mechanical shaft seals**

When installing the mechanical shaft seals please be aware that these are precision products and that they should be handled as such. The slide faces must be protected during the installation.

- B. Stationary sealing part
- C. Rotating sealing part
- D. Oil sealing ring
- E. Shaft

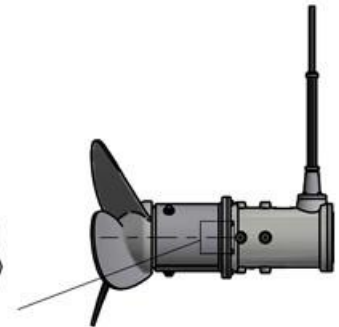
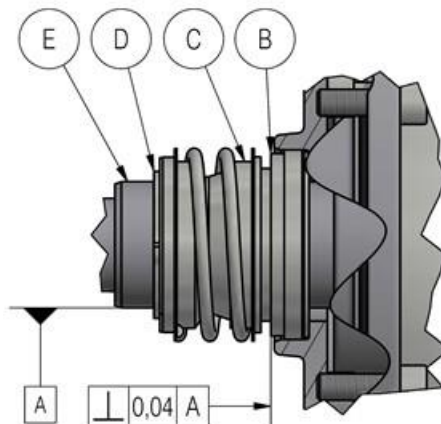

Push the stationary sealing part, pos. B, into place. Be careful not to damage the slide face during the installation.

When the stationary part is mounted and straightened with a dial gauge, wipe it off with degreaser.

The rotating sealing part, pos. C, is put over the shaft. To ease the installation put soap water on the interior side of the rubber bellows as well as on the shaft. Do not apply silicone, PTFE lubricants or oil as they will prevent the rubber bellows from sticking to the shaft. Installation arbor should be used.

Put the oil sealing ring, pos. D, on the shaft and press together the seal until the oil sealing ring is installed in the sealing ring trace. Control the sealing by turning the motor shaft.

Test the mixer for leakage by putting the motor casing and the oil chamber under an overpressure. The overpressure is to be approx. 1 bar. Leakage (air bubbles) must not appear. Oil is filled into the oil chamber/gear. During the filling, the mixer must be in a horizontal position. Oil quantity: see spare parts list.



We reserve the right to technical alterations. Translated from Danish.

## Table of contents

Introduction .....	2
Application.....	2
Warning.....	2
Note before commissioning .....	2
Service/repair .....	3
Rating plate .....	4
Power connection.....	4
Operation .....	5
Capacity .....	5
Inspection.....	5
Equipment .....	6
Disassembling/assembling .....	6

## Introduction

POPR-I is a horizontal submersible mixer. All surfaces which are in contact with the medium are made of stainless steel.

During operation the mixer is locked by a conic stop console/stop bracket fixed to the guide pipe to obtain stability. The mixing takes place by means of an electric motor coupled to the propeller by means of a planetary gear. The oil filled coupling/oil chamber between motor and gear is in an open connection with the gear, so the oil cools and lubricates the gear and the mechanical shaft seal between the oil chamber and the motor.

The propeller is installed on the output shaft of the gear. The exterior sealing system consists of a sealing ring and a mechanical shaft seal with a grease-filled chamber in between.

The following pages describe the connection and the maintenance of mixers type POPR-I.

## Application

This mixer is to be used for flow creation, mixing and homogenization of liquids with a high or low dry matter content, like e.g. wastewater, sludge and paper pulp, as well as chemical liquids.

The mixer can be placed in square and circular tanks and is to be applied only fully submerged below liquid level. When the mixer is in operation, it must be fixed on the stop bracket, which is mounted on the guide rail. If the guide rail is without a stop bracket, the mixer hangs in the wire and is stopped by a stop bracket, which is mounted on the guide rail. If more than one mixer is fitted in the tank, the horizontal setting between the mixers must not deviate more than a maximum of 5 ° from each other.

If the mixer is to be applied for other purposes, contact Landia A/S for advice.

## Warning

Please note the following points:

- Only a certified electrician is allowed to connect the unit.
- Prior to installation and start-up, check that the equipment is installed correctly to the mixer, as well as the equipment in the tank.
- Prior to the first start of the mixer, the propeller shaft must be rotated manually. This also applies if the mixer has not been in operation for a longer period.
- The electrical cable is always to be ensured by means of the chain to prevent the cable from getting into contact with the propeller. If the mixer is not supplied with a chain, the cable is to be protected against damage in another way, e.g. by means of a cable mesh.
- It must be verified that the propeller cannot touch the tank under any circumstances.
- The mixer must always be fully below liquid level during operation.
- Prior to hoisting the mixer for service/repair it is imperative that the electrical connection of the mixer is switched off or locked out. Prior to service/repair the mixer should be cleaned thoroughly.
- When the mixer is hoisted or lowered, its cable and chain are always to be placed outside the work area.
- For service/repair of mixers installed in well/tank with explosion danger/toxic gases we refer to the national safety directions as far as safety is concerned, e.g. concerning the toxic hydrogen sulphide.

## Note before commissioning

If the machine has been installed in an empty tank for more than 1 month - and with a possible risk that the machine has been exposed to high temperatures or direct sun – the grease in the propeller hub and oil level in the oil chamber must be checked/refilled. If the machine has been in storage for more than 3 months, the shaft must be rotated manually before start-up to ensure lubrication of the sealing system.

**Service/repair**

To maintain a high operating safety and a long service life without unnecessary and expensive repair it is important from the beginning to execute regular and preventive service. Maintenance should be executed according to the intervals stated in the manual. Always follow the instructions carefully and only apply the parts described by Landia A/S in the spare parts list.

Landia A/S can refer you to a service partner in your territory.

**Please note**

If spare parts not identical to the ones recommended are used at service/repair, the guarantee from Landia A/S will be voided. Spare parts can be ordered at Landia A/S or your local distributor.

For major repairs at a special workshop please contact:

Head Office:  
LANDIA A/S  
Industrivej 2  
DK-6940 Lem St.  
Tel.: +45 97 341244  
[info@landia.dk](mailto:info@landia.dk)  
[www.landia.dk](http://www.landia.dk)

UK subsidiary:  
Landia (UK) Ltd.  
Waymills Industrial Estate,  
Whitchurch,  
Shropshire SY13 1TT  
Tel: + 44 01948 661 200  
[info@landia.co.uk](mailto:info@landia.co.uk)  
[www.landia.co.uk](http://www.landia.co.uk)

Landia A/S is represented by local distributors worldwide, please call for further information.

## Rating plate

	DK-6940 Lem St.		
Type	<input type="text"/>	3~mot.nr.	<input type="text"/>
	<input type="text"/>	V	<input type="text"/>
	<input type="text"/>	A	<input type="text"/>
	<input type="text"/>	Hz	<input type="text"/>
	<input type="text"/>	kW	<input type="text"/>
	<input type="text"/>	Ins.cl.	<input type="text"/>
Cos φ	0, <input type="text"/>	RPM	<input type="text"/>
	<input type="text"/>	kg	<input type="text"/>
Eff. cl.	<input type="text"/>	Year	<input type="text"/>
	IP <input type="text"/>	Duty type	S1

Type:	Unit type
3~mot.nr.:	Serial no.
V:	Connection voltage, star/delta
A:	Nominal power consumption at full load
Hz:	Net frequency
kW:	Max. shaft power
Ins.cl.:	Insulation class
Cos φ:	Power factor
RPM:	Motor revolutions per minute
Kg:	Weight of unit
Eff. cl.:	Efficiency class
Year:	Year of manufacture
IP:	Cage class
Duty type S1	Continuous working period

The rating plate states the motor's electrical data as well as the year of manufacture and the serial no. (3~Mot.nr.). With regard to maintenance of a specific unit please state serial no. when contacting Landia.

### Please note

It is important that the electrical cable is tightened to prevent the cable from getting into contact with the propeller. The cable can be ensured against damage by means of a cable mesh or a chain.

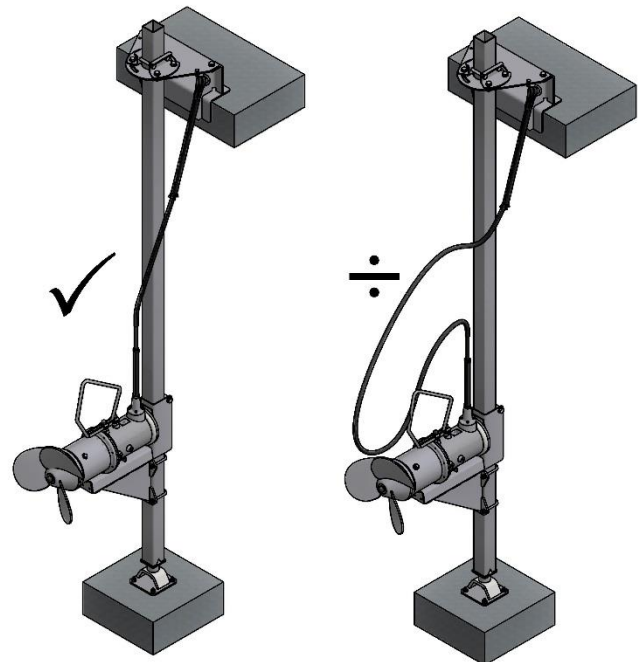

### Power connection

Every mixer is equipped with the above mentioned rating plate with technical motor data. It must be verified that the other electrical parts correspond to the motor data. For each mixer there is an electrical diagram. A protective motor switch must be applied at connection of the mixer to the mains.

### Softstarter and frequency converter

Improper motor connection and incorrectly connected/used softstarter or frequency converter can lead to faults in the machine's electric motor. Faults as a result are not covered by the machine's right of complaint.

**Only a certified electrician is allowed to connect the unit.**

## Operation

The mixers have thermal sensors as standard equipment. Often the mixers are exposed to extremely difficult operation conditions. Therefore, it is important to connect the thermal control. Burning of the motor due to overheating can thus be avoided. If the safety function has been activated the mixer must not be re-started until the cause of the circuit disconnect has been determined. Among other things the disconnection can be caused by low mains voltage, a propeller blockage or an overheated motor. The cooling period for overheated motors can be up to 1 hour.

**The unit must not operate above liquid level.**

## Capacity

The capacity of the mixer will always depend on the consistency of the medium, but especially on the design of the tank.

## Inspection

Regular inspection will ensure the mixer a long life at low costs. The oil must be changed every 6 months/4,300 hours of operation, however, min. once a year. Under difficult operation conditions, more often than every 6 months.

At inspection the outer wear bushing must be checked for wear and replaced, if needed. There are two different kinds of the outer wear bushing: a wear bushing made of stainless steel and a type designed for extremely wearing mediums. This is a stainless steel wear bushing covered with a ceramic material. The ceramic coated type is characterized by its dark colour on the wearing surface.

### With stainless steel wear bushing

If the wear bushing has deep wear traces, the propeller must be removed. A spacer can be installed between the mechanical shaft seal and the propeller in order to move the wear area of the outer oil sealing ring. If it is impossible to move the wear area, either because it has been moved previously, or the wear area is too wide, a new wear bushing must be installed.

### With ceramic coated wear bushing

Remove the propeller and check whether the surface of the wear bushing is mat/porous. If this is the case the wear bushing is worn and must be changed. It is very important to control the oil sealing ring for wear with this system. The oil sealing ring (incl. of springs) must be controlled for wear and changed if necessary.

### Mechanical shaft seal

Remove the propeller and make a visual control of the outer mechanical shaft seal. Remove rags, if any, and in case the oil is dirty, remove the seal and control it for wear.

- A. Grease nipple
- B. Grease chamber
- C. Wear bushing
- D. Oil sealing ring
- E. Mechanical shaft seal
- F. Support disk (not shown)

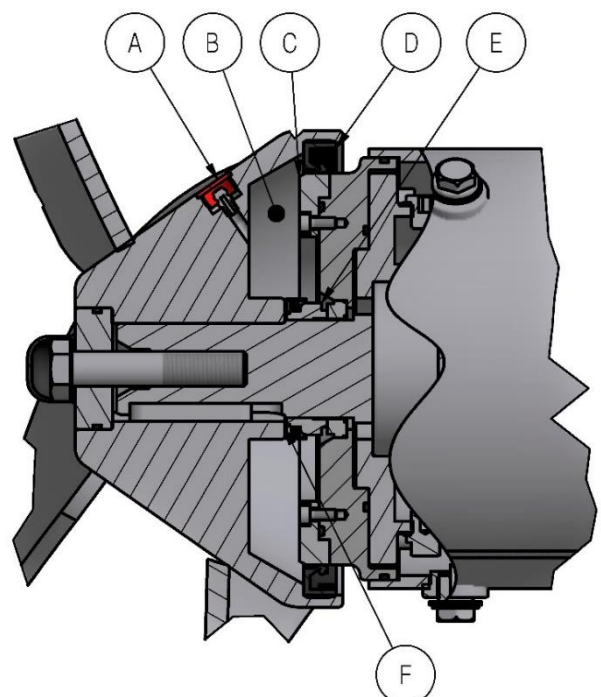



### Oil control

The oil is controlled by removing the upper oil plug A. The oil has to be clean and the level has to reach the plug hole. Oil type see spare parts list. If the oil is dirty it has to be exchanged.

- A. Upper oil plug
- B. Lower oil plug
- C. Grease nipple
- D. Inspection plug

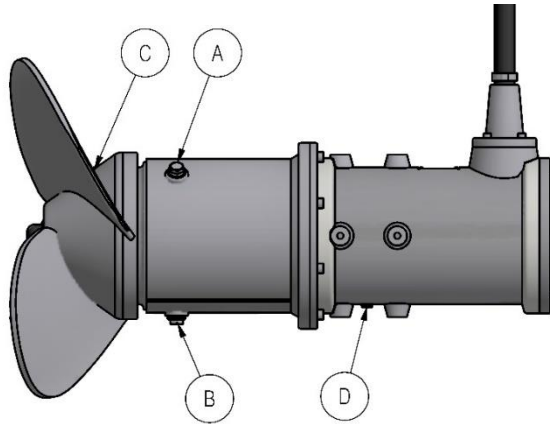

The oil is drained off by removing the plug pos. B. If the oil is dirty, seal and wear bushes must be checked for wear and contamination. Oil is filled at oil plug pos. A.

Lubricate the outer sealing system with grease (see spare parts list). This takes place through the grease nipple, pos. C, which is fixed in the propeller behind one of the propeller blades. Prior to reinstalling the propeller fill up the hub with grease lubricant.

The motor casing must be controlled in the following way: Remove the inspection plug, pos. D, beneath the motor. Any seepage of oil or liquid can be seen immediately. In case of abnormal seepage it is necessary to check the seal in the oil chamber. If in doubt, please contact Landia. If it is necessary to dry up the motor windings, contact an electric motor repair workshop.

### Equipment

The equipment should be inspected for wear and corrosion. The winch is to be lubricated with grease. Inspect brake and lock. Retighten screws. If the screws are loose remove them and lubricate with Loctite 243 prior to reinstallation.



### Disassembling/assembling

A major repair should take place at a workshop which is specialized in this type of repair. We can refer to a service partner in your territory.

Below please find some general conditions regarding disassembling/assembling of Landia mixer type POPR-I.

The drawing attached to the spare parts list shows the construction of the unit. Not all parts can/should be removed, e.g. do not press the rotor off the shaft.

When disassembling the unit, handle the mechanical seals with care as they are not shock resistant. Prior to reinstallation, all sealing surfaces must be cleaned, all O-rings must be checked and changed if necessary. Adhesive substance (e.g. Loctite) must be applied on all bolt joints. All bolts must be tightened with a torque wrench as specified in the table below.

Bolt sizes	Quality 10.9 - 12.9 Steel 	Quality A4-80 St. steel 
M6	14 Nm	10 Nm
M8	34 Nm	24 Nm
M10	67 Nm	48 Nm
M12	115 Nm	82 Nm
M16	160 Nm	137 Nm
M20	200 Nm	180 Nm
M30	620 Nm	620 Nm



**Note**

End cover, oil chamber and gear must be turned **anti-clockwise** as much as possible, seen from the end of the propeller, in order to balance the clearance in the bolt holes before the final tightening of the bolts. After installing the bearing flange control the axial clearance; as stated in the table below.

Motorseries	Acceptable clearance
ms100	0.9 ± 0.05 mm
ms132	1.0 ± 0.05 mm
ms160	1.1 ± 0.05 mm
ms180	1.5 ± 0.05 mm

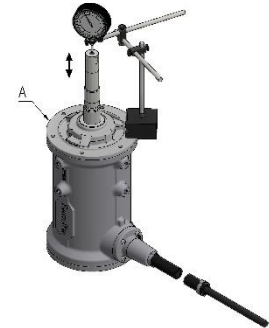

A. Bearing flange

**Installation of mechanical shaft seals**

When installing the mechanical shaft seals please be aware that these are precision products and that they should be handled as such. The slide faces must be protected during the installation.

- B. Stationary sealing ring
- C. Rotating sealing ring
- D. Locking ring
- E. Shaft
- F. Propeller hub

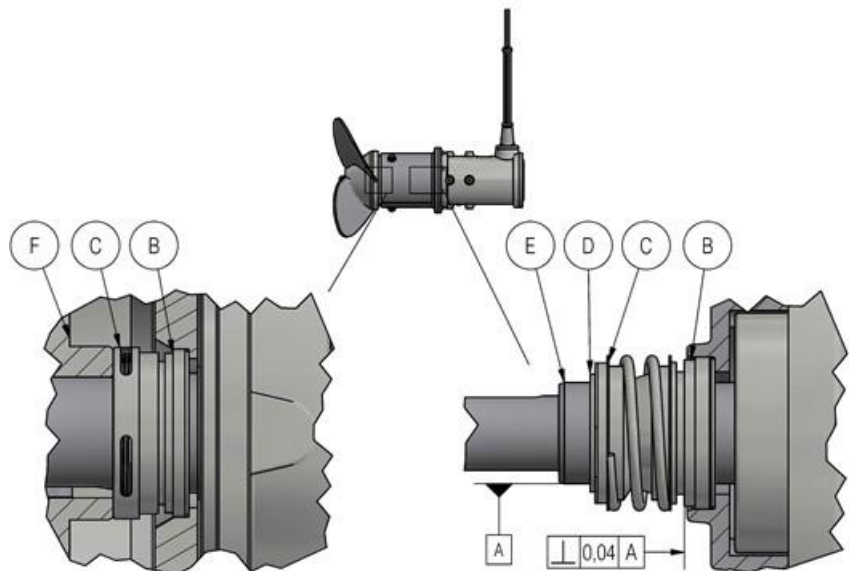

Push the stationary sealing ring, pos. B, into place. Be careful not to damage the slide face during the installation. When the stationary part is mounted and straightened with a dial gauge, wipe it off with degreaser.

The rotating sealing ring, pos. C, is inserted over the shaft. To ease the installation, put soap water on the interior side of the rubber bellows as well as on the shaft. Do not apply silicone, PTFE lubricants or oil as they will prevent the rubber bellows from sticking to the shaft. Installation arbour should be used.

The propeller hub, pos. F, keeps the outer mechanical shaft seal in place. This happens when the propeller hub is tightened against the output shaft collar. At the inner mechanical shaft seal the locking ring, pos. D, must be put on the shaft and the seal pressed together until the locking ring snaps into the locking ring groove. Inspect the sealing by turning the motor shaft.

Test the mixer for leakage by submerging it and by putting the motor casing and the oil chamber under pressure. The pressure is to be approx. 1 bar. Leakage (air bubbles) must not appear. Oil is filled into the oil chamber/gear. During the filling the mixer must be in a horizontal position. Oil quantity: see spare parts list.

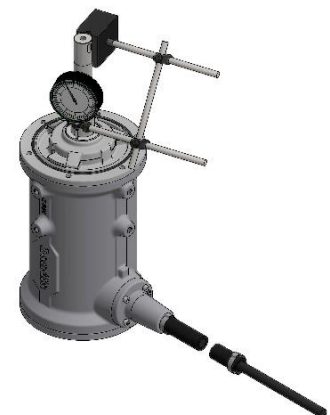

COPYRIGHT - This drawing is the property of Landia A/S and cannot be shown, copied, given to a third party or used in any other way without permission from Landia A/S.



Styret dokument

**Landia**

POPL-I  
Betonfæstelse, concrete fixing  
Beton Befestigung, Fixation sur Beton

Scale: 1:20	Sign.: HL   KSK	Date: 13-08-2007
Dwg.no.:		3740553
Revision date: 31-07-2017		

COPYRIGHT - This drawing is the property of Landia AS and cannot be shown, copied, given to a third party or used in any other way without permission from Landia AS.

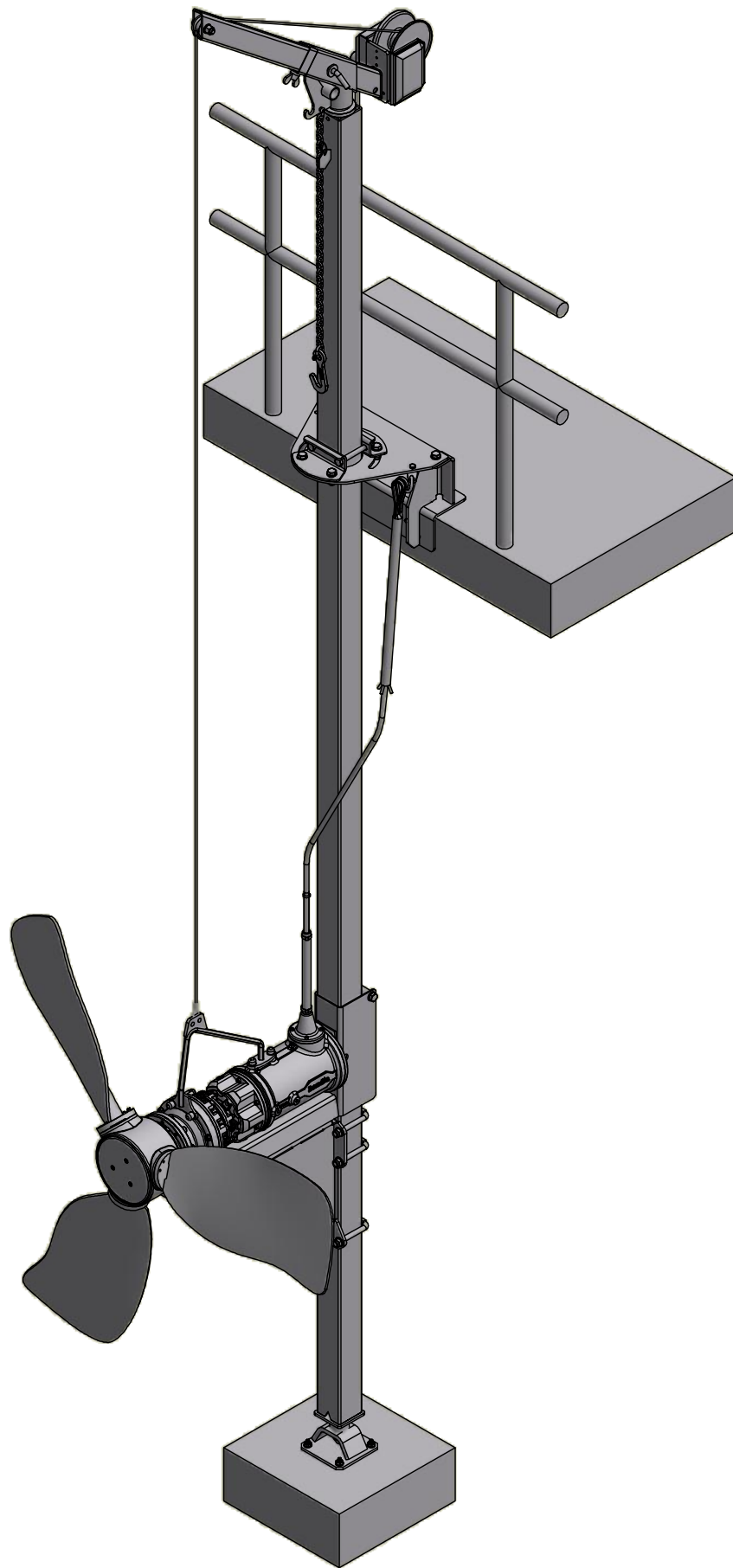

Styret dokument

**Landia**

POPL-I  
Betonbefæstelse, concrete fixing  
Beton Befestigung, Fixation sur beton

Scale: 1 : 20	Sign.: HL   KSK	Date: 14-08-2007
Dwg.no.:		3740563
Revision date: 31-07-2017		

COPYRIGHT - This drawing is the property of Landia AS and cannot be shown, copied, given to a third party or used in any other way without permission from Landia AS.



Styret dokument

**Landia**

POPL-I  
Tværdrager, crossbeam,  
Querbalcken, Fixation sur Traverse

Scale: 1 : 20	Sign.: HL   KSK	Date: 14-08-2007
Dwg.no.:		3740564
Revision date: 31-07-2017		

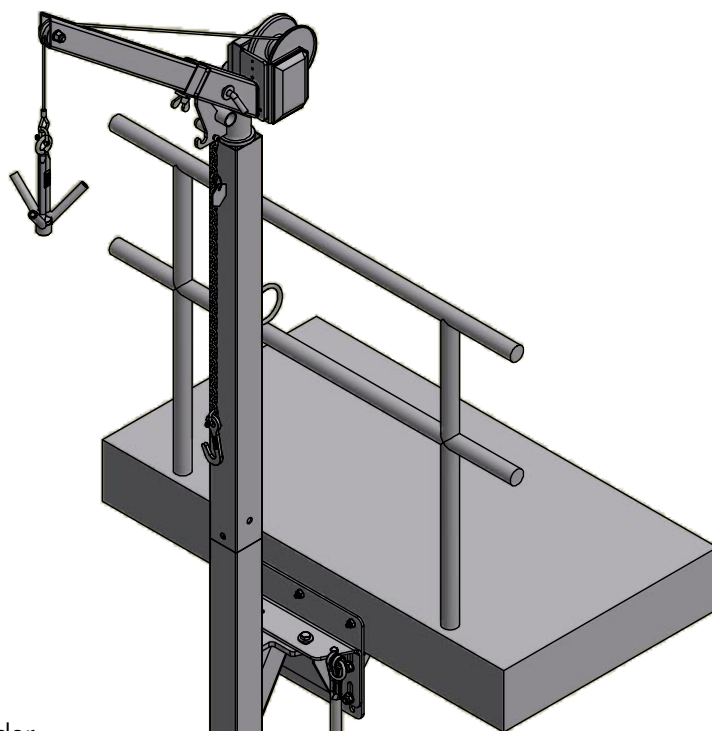

Enheden kan frit passere  
øverste befæstelse.

The unit can freely pass  
over the upper guide holder.

Die Einheit kann frei über die  
obere Befestigung passieren.

L'unité peut librement  
passer la fixation guide.

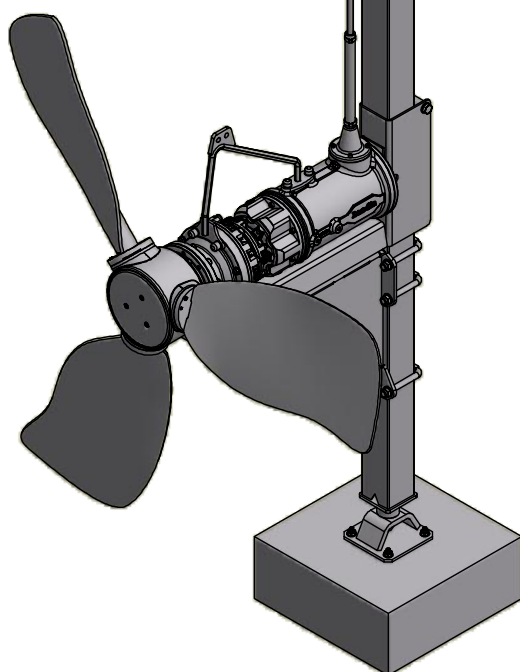

Styret dokument

COPYRIGHT - This drawing is the property of Landia AS and cannot be shown, copied, given to a third party or used in any other way without permission from Landia AS.

**Landia**

POPL-I  
Passérbar befæstelse, free passage  
Passierbare Befestigung, Passage libre

Scale: 1 : 20	Sign.: HL   KSK	Date: 14-08-2007
Dwg.no.:		3740567
Revision date: 31-07-2017		

### Propelrøreværk / Mixer / Flügelrührwerk / Agitateur Type POPL-I

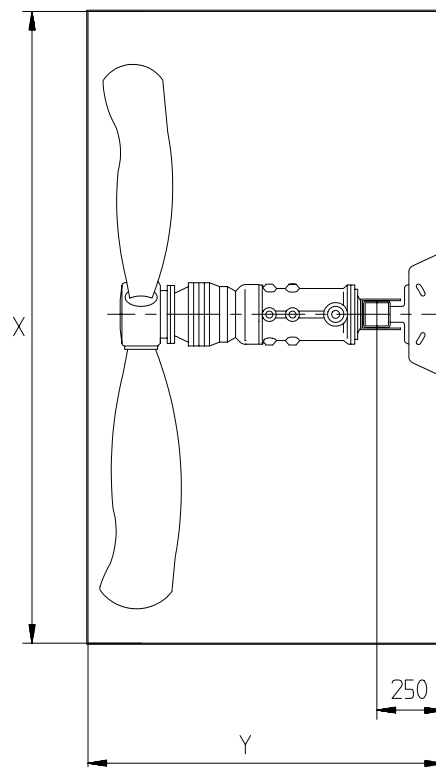
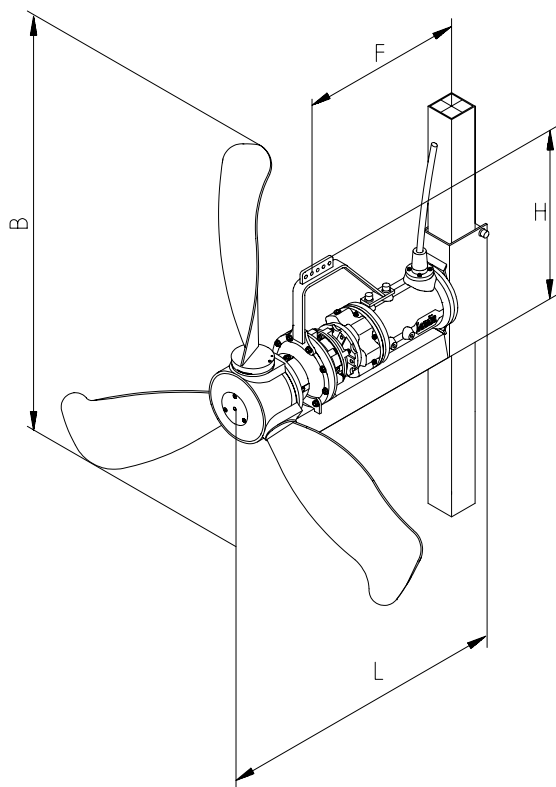

Varenr./ Article nr./ Artikel Nr./ Code no.	Effekt/ Power/ Leist./ Puiss.	Serie/ Series/ Baureihe/ Série	Prop.omdr./ Prop.rpm./ Prop.Drehzahl/ Hélice tours	Prop.nr./ Prop.no./ Prop.Nr./ Hélice no.	Prop.diam./ Prop.diam./ Prop.Durchm./ Diam. Hélice	H	B	L	F	Anbefalet mandehul Recommended man hole Empfohlenes Mannloch Trou d'homme recommandé	
Propel/Hélice		[kW]	ms.	[1/min.]	[mm]	[mm]	[mm]	[mm]	[mm]	x * y [mm]	
W1.4301	W1.0038										
1518301	1518401	1,5	100	16	981/980	ø2300	590	1800	1065	635	2300 * 1300
1518302	1518402	2,2	112	16	981/980	ø2300	595	1800	1095	635	2300 * 1300
1518503	1518603	3,0	112	23	981/980	ø2300	595	1800	1095	635	2300 * 1300
1514304	1514404	4,0	100	32	981/980	ø2300	590	1800	1065	635	2300 * 1300
1514505	1514605	5,5	112	32	981/980	ø2300	595	1800	1110	650	2300 * 1300
1618301	1618401	1,5	100	23	983/982	ø1700	590	1400	1065	635	1800 * 1300
1614302	1614402	2,2	90	32	983/982	ø1700	575	1400	975	540	1800 * 1300
1614303	1614403	3,0	100	32	983/982	ø1700	590	1400	1065	635	1800 * 1300
1614304	1614404	4,0	100	46	983/982	ø1700	590	1400	1065	635	1800 * 1300
1614305	1614405	5,5	112	46	983/982	ø1700	595	1400	1095	635	1800 * 1300

Ret til tekniske ændringer forbeholdes - We reserve the right to make technical alterations.

Technische und maßliche Änderungen vorbehalten - Sous réserve de modifications techniques.

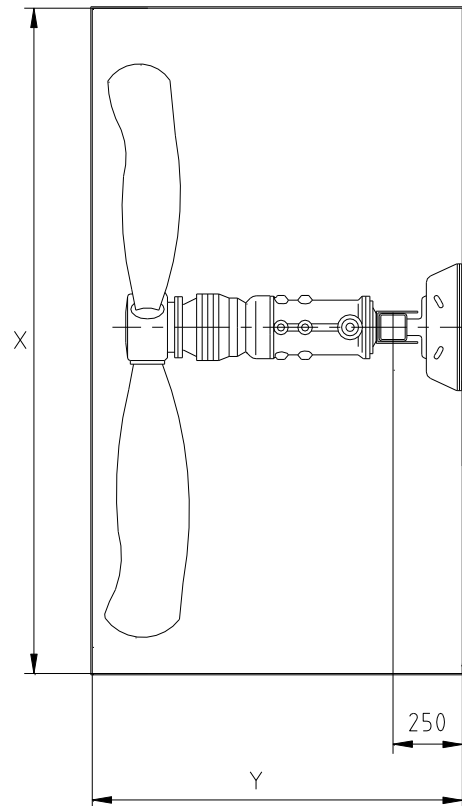
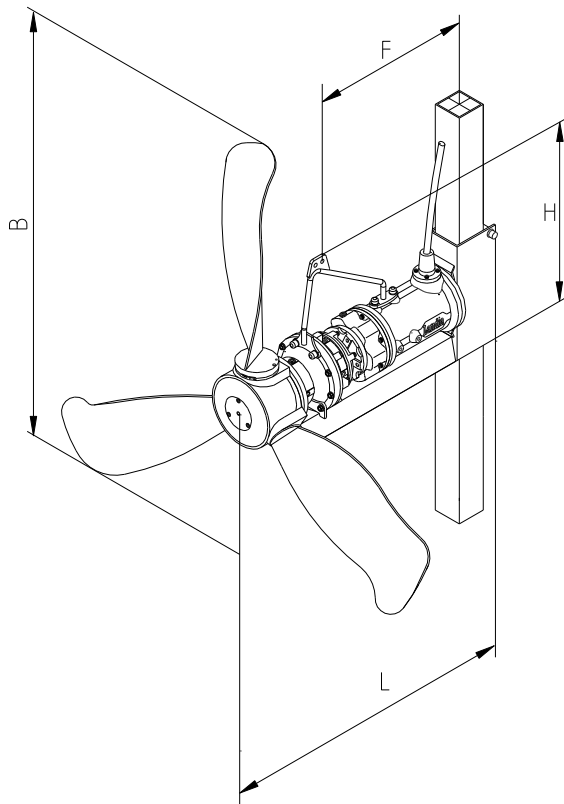
**POPL-I IE2/IE3**

**POPL-I IE2**

Varenr. Article no. Artikel Nr. Code no.	Effekt Power Leist. Puiss. [kW]	Serie Series Baureihe Série ms.	Prop.omdr. Prop.rpm. Prop.Dreh- zahl Hélice tours [rpm.]	Prop.diam. Prop.diam. Prop.Durchm. Diam. hélice [mm]	H [mm]	B [mm]	L [mm]	F [mm]	Anbefalet mandehul Recommended man hole Empfohlenes Mannloch Trou d'homme recommandé X x Y [mm]	
1536502	2,2/1,5	112	19	ø2300	635	1800	1095	635	2300 x 1300	
1536503	3,0/2,2		22						2300 x 1300	
1534504	4,0/3,0		34						2300 x 1300	
1534507	7,5/4,0	132	34	ø1700	695	1400	1165	635	2300 x 1300	
1636601	1,5/1,1	112	22		635				1095	1800 x 1300
1634602	2,2/1,5	100	33		655				1065	1800 x 1300
1634603	3,0/2,2	112	34	ø1700	635	1400	1095	635	1800 x 1300	
1634604	4,0/3,0		47						1800 x 1300	
1634607	7,5/4,0		132						47	695

**POPL-I IE3**

Varenr. Article no. Artikel Nr. Code no.	Effekt Power Leist. Puiss. [kW]	Serie Series Baureihe Série ms.	Prop.omdr. Prop.rpm. Prop.Dreh- zahl Hélice tours [rpm.]	Prop.diam. Prop.diam. Prop.Durchm. Diam. hélice [mm]	H [mm]	B [mm]	L [mm]	F [mm]	Anbefalet mandehul Recommended man hole Empfohlenes Mannloch Trou d'homme recommandé X x Y [mm]
1566504	4,0/3,0	132	22	ø2300	695	1800	1150	635	2300 x 1300
1564507	7,5/4,0	132	34				1165		
1664607	7,5/4,0	132	47	ø1700	1400	1150	635	1800 x 1300	

Ret til tekniske ændringer forbeholdes - We reserve the right to make technical alterations.  
 Technische und maßliche Änderungen vorbehalten - Sous réserve de modifications techniques.

# POPL-I

The POPL-I is a slow-speed flowmaker for mixing large volumes of water. A unique function of the POPL-I is the ability to change the angle of the propeller blades. This special feature, which is only offered by Landia, optimizes energy consumption.

## APPLICATION EXAMPLES

- Oxidation ditches
- Anoxic and anaerobic tanks
- MBBR reactors

## PROPELLER RPM

Propeller speed can vary between 19–47 rpm.

Specific propeller rpm is listed under

Overall Dimensions



## MATERIAL OF CONSTRUCTION

Motor housing	Cast iron EN-GJL-250
Propeller hub	Cast iron EN-GJL-250
Propeller blades	Stainless steel W1.4301/AISI304
Gear	Cast iron EN-GJL-250
Output shaft gear	Shaft steel W1.6511/9840 (no contact with the liquid)
Bolts	A4
External sealing set	3 oil sealing rings made of nitrile Wear bush made of stainless steel W1.4301/AISI304 (ceramic coating optional) Wear bush made of steel W1.2363
Interior sealing set	Mechanical shaft seal: silicon carbide/silicon carbide
Oil type	SP 220 GS 220 (with moisture detection)
Grease type	High temperature grease



## SERVICE AND MAINTENANCE

Recommended service interval/oil change	Maximum 4,300 operating hours/minimum once a year
Motor	Lifetime lubricated bearings (no maintenance required)
Gear	Periodic oil change Calculated service life >100,000 operating hours
Propeller	Periodic lubrication with grease

## SURFACE TREATMENT

2-component coating: RAL 7005 (Mouse Grey)

Mouse Grey

## ELECTRICAL CABLE

H07RN-F/S07RN-F EUCAFLEX<sup>Plus</sup> Cable.

Resistant to oil and UV radiation.

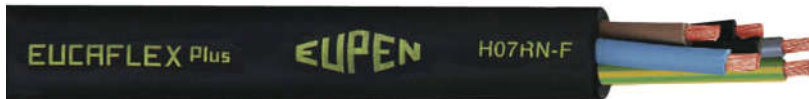

Number of conductors:

H07RN-F 7G1.5 mm<sup>2</sup> (Not used in United Kingdom)

H07RN-F 7G2.5 mm<sup>2</sup>

As standard supplied with 7 m of cable (extra length available upon request).

## MONITORING FUNCTIONS

Bimetal thermal sensors 120 °C

Moisture detection system (optional)

## DESIGN

The Landia POPL-I is a slow-speed mixer, or flowmaker, for mixing and creating flow in large volumes with very low energy consumption.

The Landia POPL-I is one of a kind because of its adjustable propeller blades. This enables fine adjustments in the energy consumption simply by changing the angle of the propeller blades. The propeller blades of the POPL-I flowmaker are made of stainless steel.

The POPL-I has a triple sealing system and a grease chamber in the propeller hub.

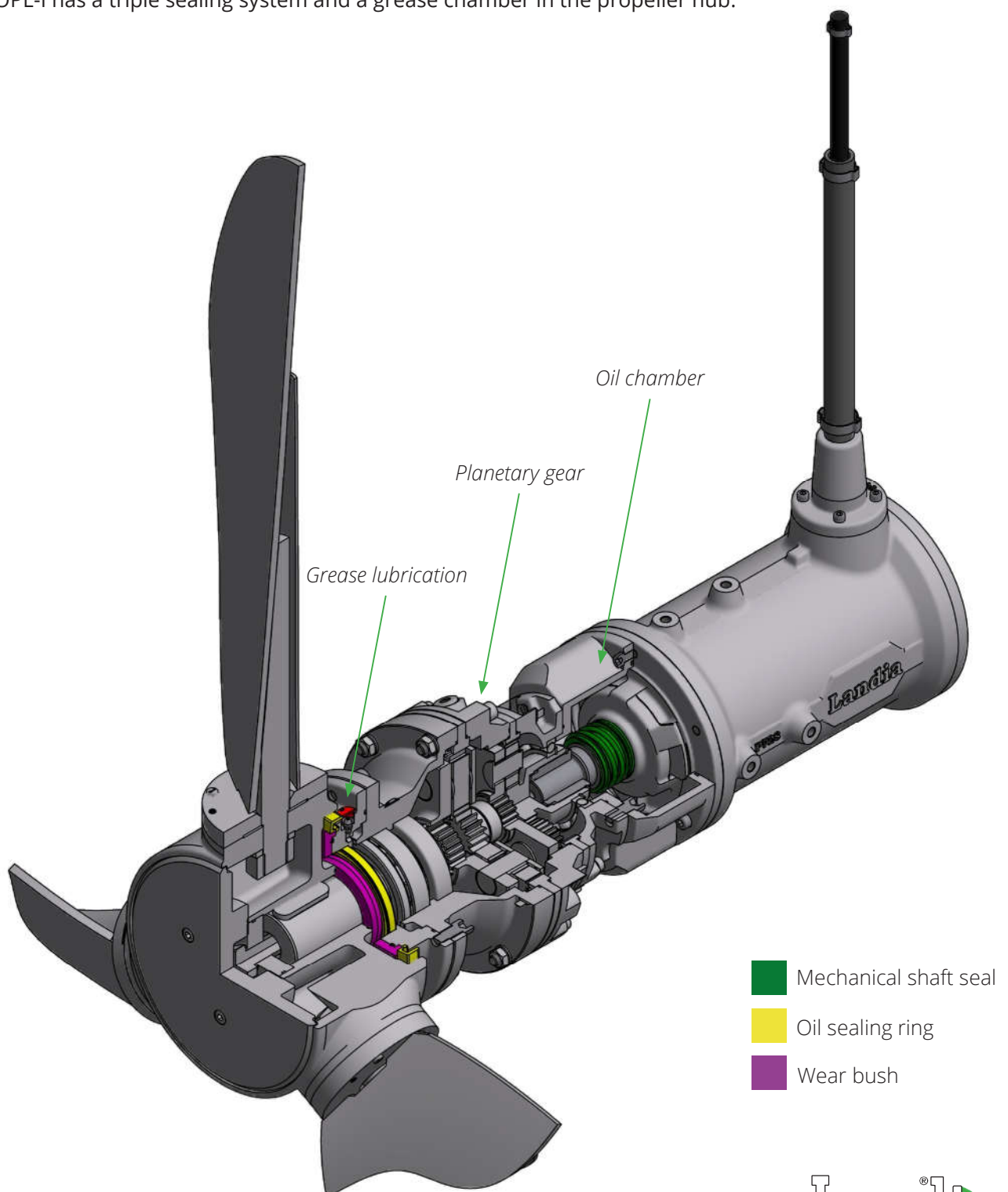

**ELECTRICAL DATA**

Motor type	3-phase AC motor
Nominal voltage	400 V
Minimum voltage allowed	360 V
Nominal frequency	50 Hz
Applicable for VFD operation	Yes
Ingress protection rating	IP 68
Insulation class	F
Start function	Soft starter required
ATEX classification	II 2 G Ex db h IIB T4 Gb (Option, only available for specific models)

Model	Item number	Nominal power	Motor	Full load current (400 V)	Connection method	Start current (DOL)	cos phi	Efficiency
		[kW]	[rpm]	[A]	Y/Δ	[A]		[%]
POPL-I 1.5/1.1 kW-22 rpm, ø1,700 IE2	1636601	3.0	955	7.1	Δ	50	7.3	83.3
POPL-I 2.2/1.5 kW-34 rpm, ø1,700 IE2	1634602	2.2	1,455	4.8	Y	45	0.77	84.3
POPL-I 3.0/2.2 kW-34 rpm, ø1,700 IE2	1634603	3.0	1,460	6.5	Δ	63	0.77	85.5
POPL-I 4.0/3.0 kW-47 rpm, ø1,700 IE2	1634604	4.0	1,460	7.6	Δ	63	0.86	87.6
POPL-I 7.5/4.0 kW-47 rpm, ø1,700 IE2	1634607	7.5	1,470	14.5	Δ	123	0.82	89.9
POPL-I 2.2/1.5 kW-19 rpm, ø2,300 IE2	1536502	3.0	955	7.1	Δ	50	7.3	83.3
POPL-I 3.0/2.0 kW-22 rpm, ø2,300 IE2	1536503	3.0	955	7.1	Δ	50	0.73	83.3
POPL-I 4.0/3.0 kW-34 rpm, ø2,300 IE2	1534504	4.0	1,460	7.6	Δ	63	0.86	87.6
POPL-I 7.5/4.0 kW-34 rpm, ø2,300 IE2	1534507	7.5	1,470	14.5	Δ	123	0.82	89.9

For voltages others than 400 V/50 Hz please refer to the attached Appendix.

## OVERALL DIMENSIONS

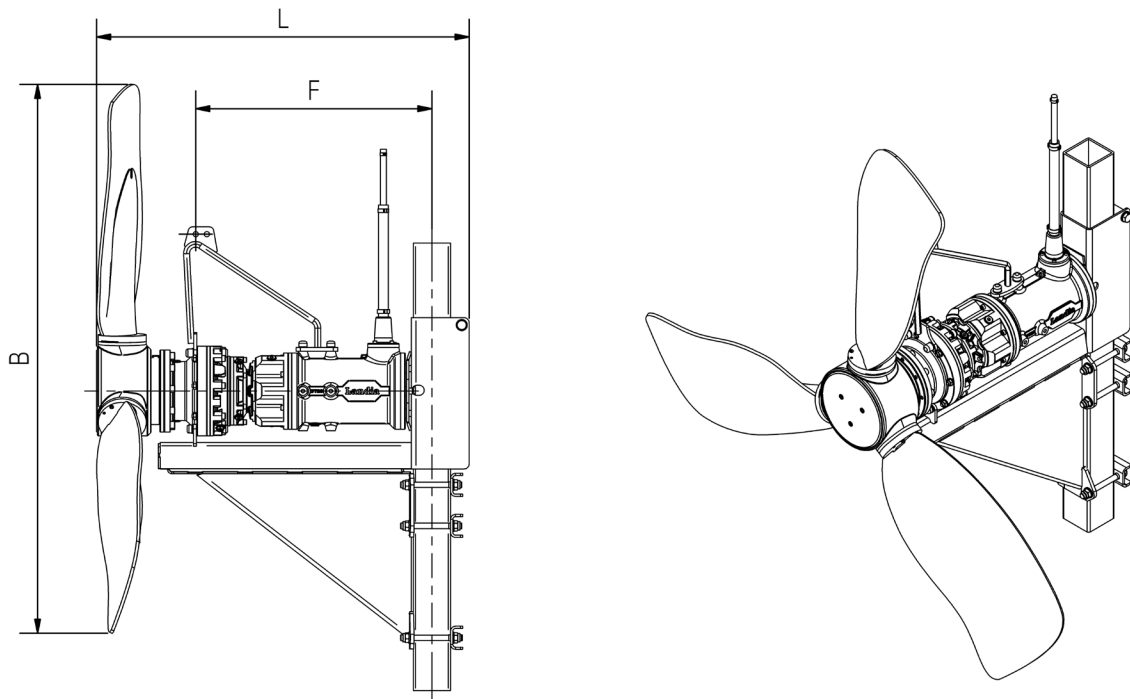

Model	Item number	Propeller diameter [mm]	B [mm]	F [mm]	L [mm]	Guide pipe [mm]	Weight [kg]
POPL-I 1.5/1.1 kW-22 rpm, IE2	1636601	ø1,700	1,400	635	1,095	100x100	180
POPL-I 2.2/1.5 kW-34 rpm, IE2	1634602	ø1,700	1,400	635	1,065	100x100	210
POPL-I 3.0/2.2 kW-34 rpm, IE2	1634603	ø1,700	1,400	635	1,095	100x100	220
POPL-I 4.0/3.0 kW-47 rpm, IE2	1634604	ø1,700	1,400	635	1,095	100x100	230
POPL-I 7.5/4.0 kW-47 rpm, IE2	1634607	ø1,700	1,400	635	1,150	100x100	270
POPL-I 2.2/1.5 kW-19 rpm, IE2	1536502	ø2,300	1,800	635	1,095	100x100	260
POPL-I 3.0/2.0 kW-22 rpm, IE2	1536503	ø2,300	1,800	635	1,095	100x100	260
POPL-I 4.0/3.0 kW-34 rpm, IE2	1534504	ø2,300	1,800	635	1,095	100x100	227
POPL-I 7.5/4.0 kW-34 rpm, IE2	1534507	ø2,300	1,800	635	1,165	100x100	286

We reserve the right to make technical changes.

## Table of contents

Introduction .....	2
Application.....	2
Warning.....	2
Note before commissioning .....	2
Service/repair .....	2
Rating plate .....	4
Power connection.....	4
Operation .....	5
Capacity .....	5
Inspection.....	5
Oli Control .....	6
Equipment .....	6
Propeller adjustment .....	6
Disassembling/assembling the unit.....	7
Installation of mechanical shaft seals .....	8

## Introduction

POPL-I is a low-speed horizontal submersible mixer.

The unit is placed approximately in the middle of the cross section of the liquid and in operation it will provide sufficient liquid velocity to maintain suspension.

During operation, the mixer is locked by a conic stop console fixed to the guide pipe to obtain stability.

The mixing takes place by means of an electric motor coupled to the propeller ( $\varnothing 1700$  mm or  $\varnothing 2300$  mm) by means of a planetary gear.

The oil filled coupling/oil chamber between motor and gear is in open connection with the gear, so the oil cools and lubricates the gear and the mechanical shaft seal between the oil chamber and the motor.

The hub is installed on the propeller shaft, the output shaft of the gear.

The three propeller blades are adjustable for energy optimization.

The exterior sealing system consists of three sealing rings with grease filled chambers between these.

The following pages describe the connection and the maintenance of mixers POPL-I.

## Application

This mixer is to be used for flow creation, mixing and homogenization of liquids with a low dry matter content, like e.g. wastewater.

The mixer can be placed in square and circular tanks and is to be applied only fully submerged below liquid level.

If the mixer is to be applied for other purposes, contact Landia A/S for advice.

## Warning

please note the following points:

- Only a certified electrician is allowed to connect the unit.
- Prior to installation and commissioning ensure that the equipment is installed correctly and is fixed to the mixer, as well as ensure that the equipment in the tank is fixed safely.
- Prior to the first start of the mixer, the propeller shaft must be rotated manually. This also applies if the mixer has not been in operation for a longer period.
- The electrical cable is always to be tightened by means of the chain to prevent the cable from getting into contact with the propeller. If the mixer is not supplied with a chain, the cable is to be protected against damage in another way, e.g. by means of a cable mesh.
- It must be ensured that the propeller cannot touch the tank.
- It is always to be ensured that the mixer is fully below liquid level during operation.
- Prior to hoisting the mixer at service/repair, it is always to be ensured that the electrical connection of the mixer is switched off or locked. Prior to service/repair, the mixer should be cleaned thoroughly.
- When the mixer is hoisted or lowered, its cable and chain are always to be placed outside the work area.
- For service/repair of mixers installed in well/tank with explosion danger/toxic gases we refer to the national safety directions as far as safety is concerned, e.g. concerning the toxic hydrogen sulphide.

## Note before commissioning

If the machine has been installed in an empty tank for more than 1 month - and with a possible risk that the machine has been exposed to high temperatures or direct sun – the grease in the propeller hub and oil level in the oil chamber must be checked/refilled. If the machine has been in storage for more than 3 months, the shaft must be rotated manually before start-up to ensure lubrication of the sealing system.

## Service/repair

To maintain a high operating safety and a long service life without unnecessary and expensive repair it is important from the beginning to execute regular and preventive service. Maintenance should be executed according to the intervals stated in the manual. Always follow the instruction carefully and only apply the parts described by Landia A/S in the spare parts list. If you do not want to execute the service yourself we can offer you a service agreement - please call for further information.

**Please note**

If spare parts not identical to the recommended are applied at service/repair, the guarantee from Landia A/S will be annulled. Spare parts can be ordered at Landia A/S or your local distributor.

For major repairs at a special workshop please contact:

Head Office:  
LANDIA A/S  
Industrivej 2  
DK-6940 Lem St.  
Tel.: +45 97 341244  
[info@landia.dk](mailto:info@landia.dk)  
[www.landia.dk](http://www.landia.dk)

UK subsidiary:  
Landia (UK) Ltd.  
Waymills Industrial Estate,  
Whitchurch,  
Shropshire SY13 1TT  
Tel: + 44 01948 661 200  
[info@landia.co.uk](mailto:info@landia.co.uk)  
[www.landia.co.uk](http://www.landia.co.uk)

Landia A/S is represented by local distributors worldwide, please call for further information.

## Rating plate

	DK-6940 Lem St.		
Type	<input type="text"/>	3~mot.nr.	<input type="text"/>
	<input type="text"/>	V	<input type="text"/>
	<input type="text"/>	A	<input type="text"/>
	<input type="text"/>	Hz	<input type="text"/>
	<input type="text"/>	kW	<input type="text"/>
	<input type="text"/>	Ins.cl.	<input type="text"/>
Cos φ	0, <input type="text"/>	RPM	<input type="text"/>
	<input type="text"/>	kg	<input type="text"/>
Eff. cl	<input type="text"/>	Year	<input type="text"/>
	IP <input type="text"/>	Duty type	S1

Type:	Unit type
3~mot.nr.:	Serial no.
V:	Connection voltage, star/delta
A:	Nominal power consumption at full load
Hz:	Net frequency
kW:	Max. shaft power
Ins.cl.:	Insulation class
Cos φ:	Power factor
RPM:	Motor revolutions per minute
Kg:	Weight of unit
Eff. cl.:	Efficiency class
Year:	Year of manufacture
IP:	Cage class
Duty type S1	Continuous working period

The rating plate states the motor's electrical data as well as the year of manufacture and the serial no. (3~Mot.nr.). With regard to maintenance of a specific unit please state serial no. when contacting Landia.

### Please note

It is important that the electrical cable is tightened to prevent the cable from getting into contact with the propeller. The cable can be ensured against damage by means of a cable mesh or a chain.

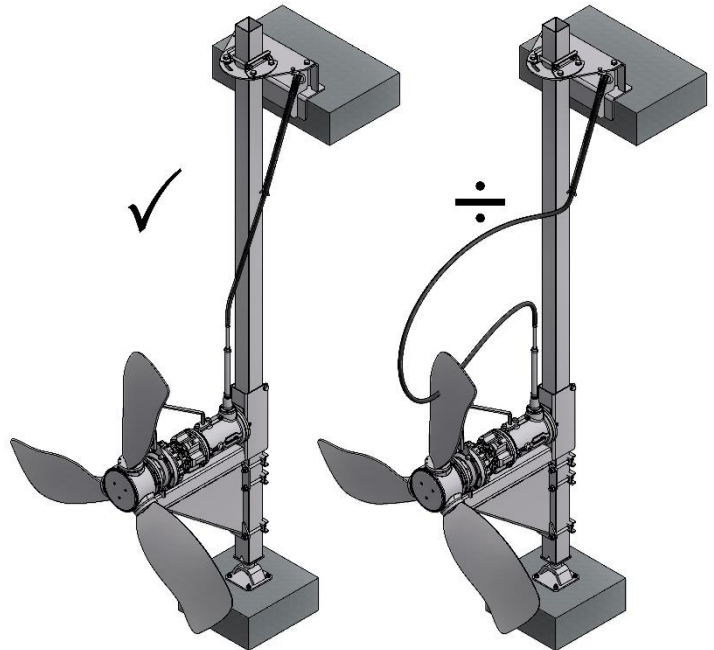

### Power connection

Every mixer is equipped with the above mentioned rating plate with technical motor data. It must be ensured that the other electrical parts correspond to the motor data. For each mixer there is an electrical diagram. For POPL-I mixers a protective motor switch and a softstarter must be applied.

### Softstarter and frequency converter

Improper motor connection and incorrectly connected/used softstarter or frequency converter can lead to faults in the machine's electric motor. Faults as a result are not covered by the machine's right of complaint.

**Only a certified electrician is allowed to connect the unit.**



## Operation

The mixers have thermal sensors as standard equipment.

Often the mixers are exposed to extremely difficult operation conditions. Therefore, it is important to connect the thermal control. Burning of the motor due to overheating can thus be avoided. If the safety function has been activated the mixer must not be re-started until the cause of the disconnection has been found.

Among other things the disconnection can be caused by reduced mains voltage, a propeller blockage, or an overheated motor. The cooling period for overheated motors can be up to 1 hour.

**The agitator must never run above fluid level**

## Capacity

The mixer's capacity will always be dependent on the consistency of the medium, but especially on the design of the tank.

## Inspection

Regular inspection will ensure a long life at low costs. The oil must be changed every 6 months/4,300 hours of operation, however, min. once a year. Under difficult operation conditions, more often than every 6 months.

At inspection, the outer wear bush and the outer sealing ring must be checked.

There are two different kinds of the outer wear bush: a wear bush made of stainless steel and a type designed for extremely wearing mediums. This is a stainless-steel wear bush, covered with a ceramic material. The ceramic coated type is characterized by its dark colour on the wearing surface.

### With stainless steel wear bush

If the wear bush has deep wear traces, the propeller must be uninstalled.

A spacer pos. F can be installed between the interior wear bush pos. C, and the propeller in order to move the wear area for the exterior oil sealing ring pos. G. If it is impossible to move the wear area, either because it has been moved previously, or the wear area is too broad, a new wear bush must be installed. The oil sealing ring must be checked.

### With ceramic coated wear bush

Uninstall the propeller and check if the surface on the wear bush is mat/ porous. If this is the case the wear bush pos. B, is worn and must be changed. It is very important to check the oil sealing ring pos. G for wear with this system.

When the propeller has been removed, check the interior wear bush pos. C for wear traces. This wear bush can be turned once for a new wear area. The oil sealing rings pos G and H (incl. springs) must be inspected for wear and replaced if necessary.

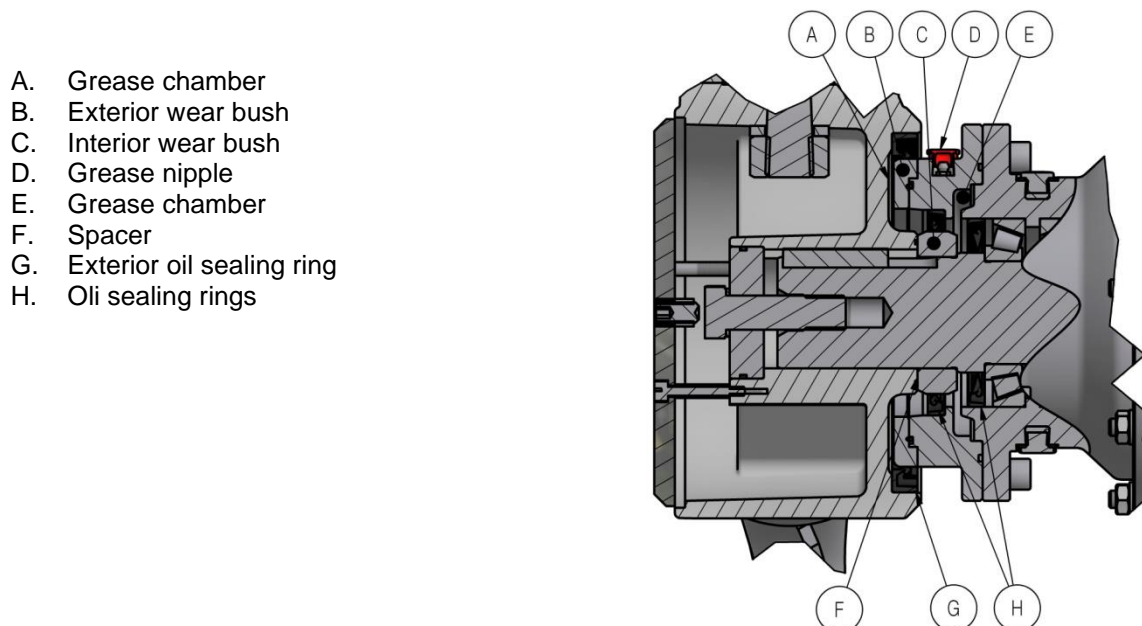

- A. Grease chamber
- B. Exterior wear bush
- C. Interior wear bush
- D. Grease nipple
- E. Grease chamber
- F. Spacer
- G. Exterior oil sealing ring
- H. Oli sealing rings

## Oli Control

The oil is checked by removing the upper oil plug pos. C (ms100-132) on the oil chamber or pos. B (ms90) on the gear. The oil has to be clean and the level must reach the plug hole. Oil type: see spare parts list. If the oil is dirty it has to be exchanged.

- A. Grease chamber
- B. Upper oil plug, gear
- C. Upper oil plug, oil chamber
- D. Bottom oil plug, gear
- E. Bottom oil plug, oil chamber
- F. Inspection plug

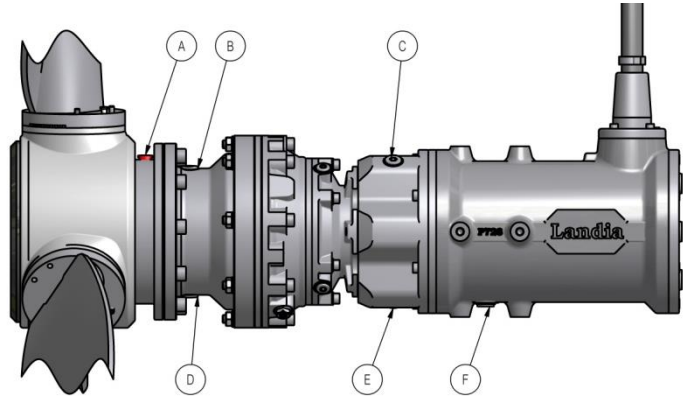

The oil is drained off by removing the plugs pos. E and pos. D (ms100-132) or pos. D (ms90). If the oil is dirty, seal and wear bushes must be checked for wear and contamination.

During filling of oil through oil plug pos. C (ms100-132) the oil plug pos. B must be removed to allow the venting of the gear. For ms.90 oil is filled at oil plug pos. B on the gear.

Grease lubricates the outer sealing system (see spare parts list). This takes place by removing the stop screw pos. A placed right behind the propeller hub and then lubricate through the grease nipple.

Prior to reinstalling the propeller, fill up the back chamber of the hub with grease.

The motor casing must be checked as follows:

Remove the inspection plug (pos. F) beneath the motor. If oil or liquid has leaked, this can be seen.

It will be necessary to check the seal in the oil chamber if abnormal leakage has occurred. In case of doubt, Landia can be contacted.

If it is necessary to dry up the motor windings, contact a special workshop.

## Equipment

The equipment should be checked for wear and corrosion. The winch is to be grease lubricated. Check brake and lock. Re-tighten screws. If the screws are loose, remove them and lubricate with an adhesive substance (e.g. Loctite) prior to reinstallation.

## Propeller adjustment

If it is required to change the liquid velocity in the tank, the propellers can be adjusted. Remove the cover of the propeller hub. Loosen the propeller blades with a wrench (46 mm). Remove pins, if any. Make a new adjustment. See the markings on hub and blades. The blades are tightened in a new position. It is important to counter hold the propeller blade with a large wrench. An adhesive substance must be applied when tightening the propeller blades.

## Important

Be very careful with the adjustment as a small inaccuracy will cause a major out-of-balance and thus extra mechanical wear of the equipment and the unit.

Next to the adjustment and the clamping ensure the propeller blades with 6 mm tightening pins. Install the hub cover and check the power consumption.

Be careful not to over tighten the screws in the hub cover. Do not apply adhesive substance on the screws.

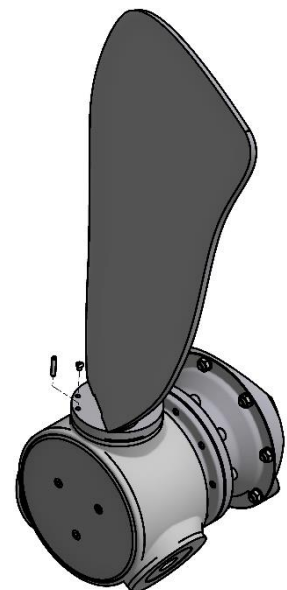

## Disassembling/assembling the unit

Note: a major repair should take place at a special workshop.

Below please find some general conditions regarding disassembling/assembling of Landia mixer type POPL-I.

The drawing attached to the spare parts list shows the construction of the unit. Not all parts can/should be dismantled, e.g. do not press the rotor off the shaft.

When disassembling the unit handle the mechanical seals with care as they are not shock resistant.

Prior to reinstallation all sealing surfaces must be cleaned, all O-rings must be checked and changed, if necessary.

Adhesive substance (e.g. Loctite) must be applied on all bolt joints. All bolts are tightened with a tightening torque acc. to the table below.

Bolt sizes	Quality 10.9 – 12.9 Steel	Quality A4-80 St. steel
M6	14 Nm	10 Nm
M8	34 Nm	24 Nm
M10	67 Nm	48 Nm
M12	115 Nm	82 Nm
M16	160 Nm	137 Nm
M20	200 Nm	180 Nm
M30	620 Nm	620 Nm

### Note

End cover, oil chamber and gear must be turned **clockwise** as much as possible, seen from the end of the propeller, in order to balance the margin in the bolt holes before the final tightening of the bolt.

Be careful not to over tighten the screws on the hub cover. Do not use neither torque wrench nor adhesive substance here.

After installing the bearing flange, check the axial space as stated in the table below.

Motor series	Acceptable margin
ms 90	$0,7 \pm 0,05$ mm
ms100	$0,9 \pm 0,05$ mm
ms112	$1,0 \pm 0,05$ mm
ms132	$1,0 \pm 0,05$ mm

A. Bearing flange

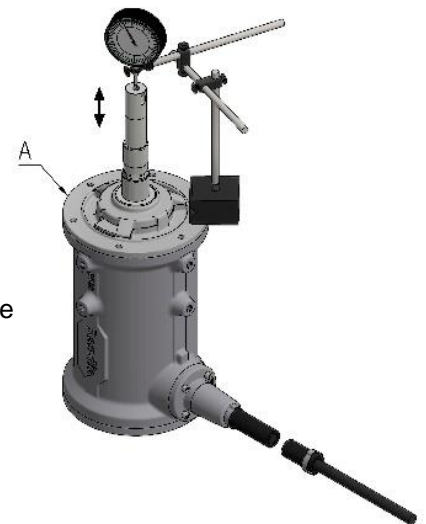

### Installation of mechanical shaft seals

When installing the mechanical shaft seals please be aware that these are precision products and that they should be treated as such. The slide faces must be protected during the installation.

- B. Stationary sealing part
- C. Rotating sealing part
- D. Locking ring
- E. Shaft

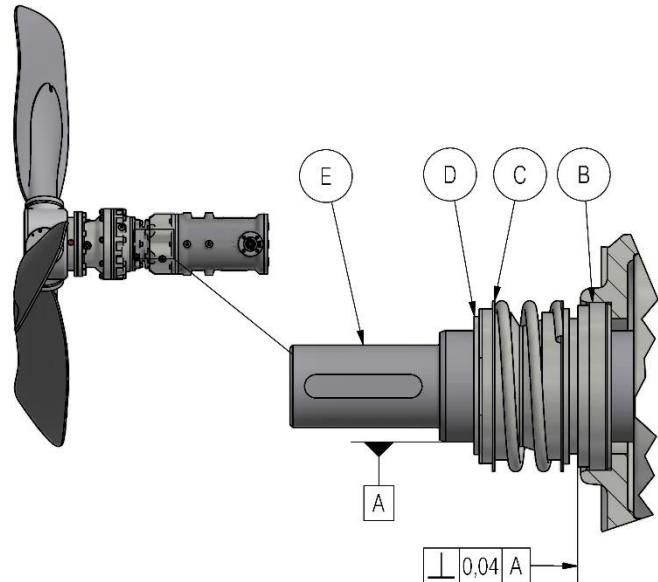

Push the stationary sealing part pos. B into place. Be careful not to damage the slide face during the installation. When the stationary part is mounted and straightened with a dial gauge, wipe it off with degreaser.

The rotating sealing part pos. C is put over the shaft. To ease the installation, put soapy water on the interior side of the rubber bellows as well as on the shaft. Do not apply silicone, PTFE lubricants or oil as they will prevent the rubber bellows from sticking to the shaft. Installation arbor should be used. Put the locking ring pos. D on the shaft and press together the seal until the locking ring is installed in the locking ring trace. Check the sealing by turning the motor shaft.

Test the mixer for leakage by applying an overpressure to the motor housing and the oil chamber. The overpressure is approx. 1 bar. Leakage (air bubbles) must not appear. Oil is filled into the oil chamber/gear. During the filling, the mixer must be in a horizontal position.

Oil quantity: see spare parts list.

Repair of surface coating is necessary prior to operation start. See instruction for maintenance of surface coating.

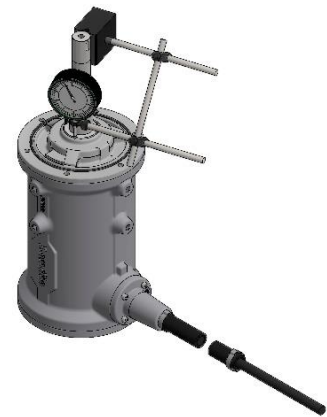

COPYRIGHT - This drawing is the property of Landia AS and cannot be shown, copied, given to a third party or used in any other way without permission from Landia AS.

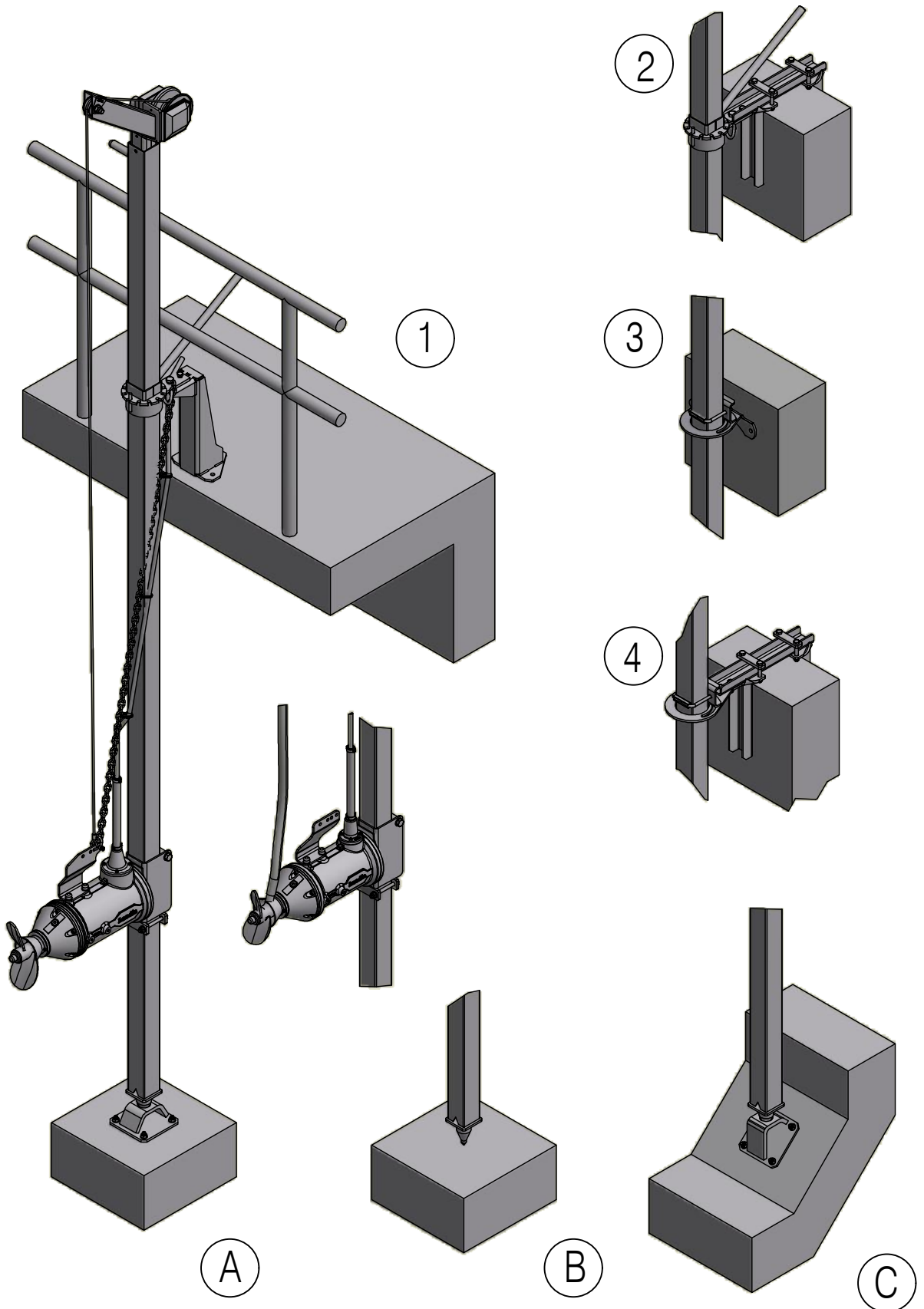

Styret dokument

**Landia**

POD-I/PODB-I ms.80-132  
Betonbefæstelser, Concrete fixings  
Beton befestigung, Fixation sur beton

Scale: 1 : 20	Sign.: AAT   KSK	Date: 12-07-2018
Dwg.no.:		3740557
Revision date: 25-07-2018		

COPYRIGHT - This drawing is the property of Landia AS and cannot be shown, copied, given to a third party or used in any other way without permission from Landia AS.

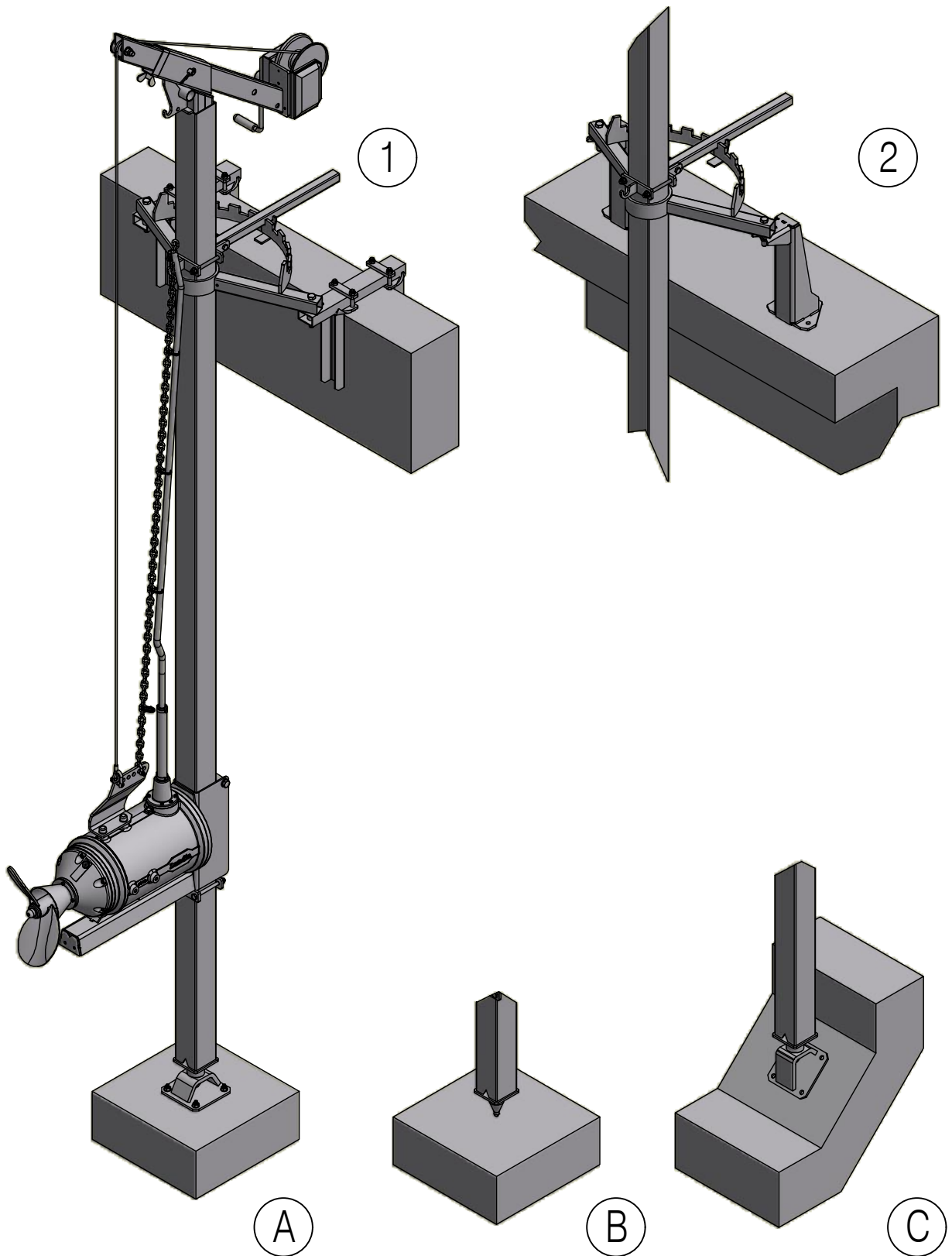

Styret dokument

**Landia**<sup>®</sup>

POD-I / PODR-I ms. 160  
Betonbefæstelser. Concrete fixings  
Beton Befestigung. Fixation sur beton

Scale:	Sign.:	Date:
1 : 20	LBO   KSK	03-10-2017
Dwg.no.:		3740554
Revision date: 25-07-2018		

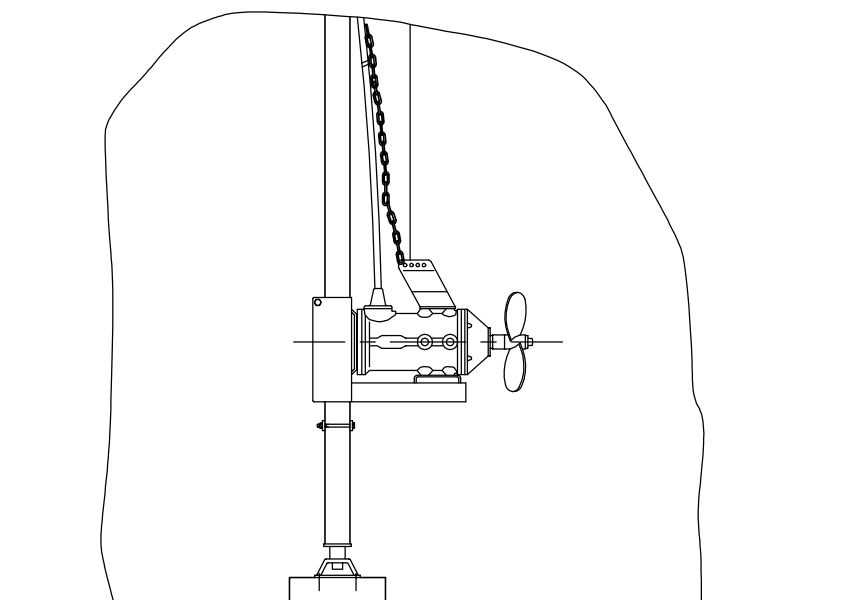
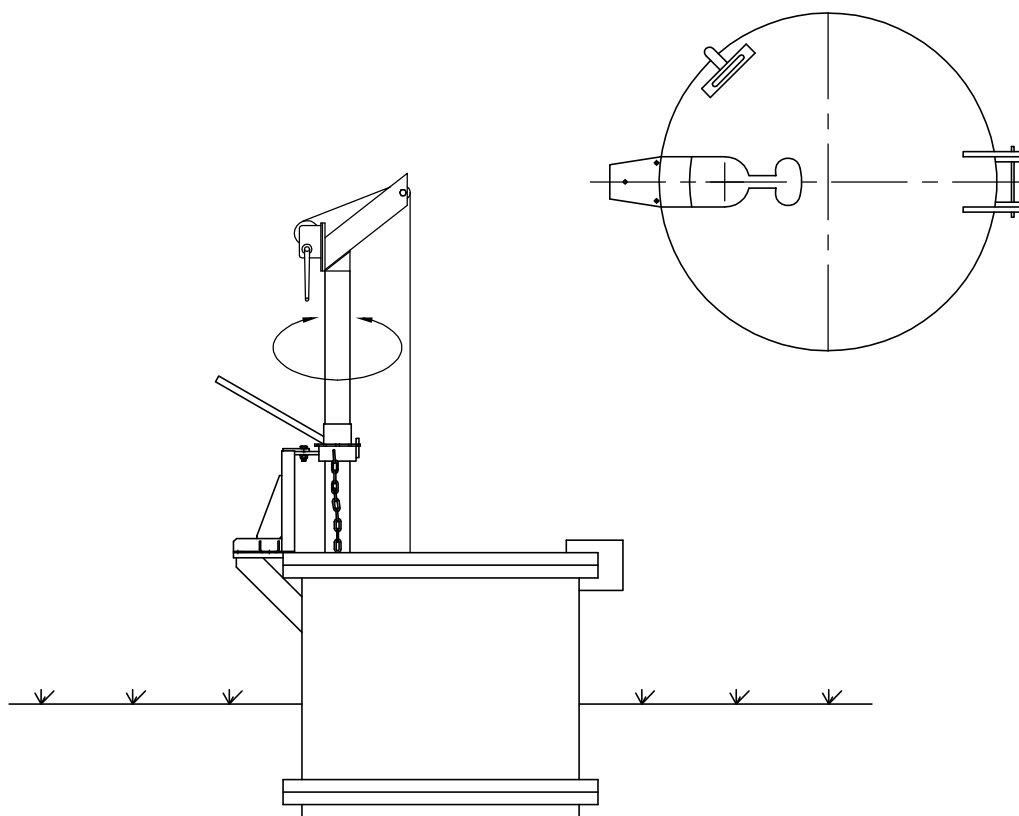

Styret dokument

**Landia**

PODR-I  
 Ferrosulfattank/glasfibertank  
 Principtegning

Scale: 1:30	Sign.: HL   PH	Date: 01.11.1993
Dwg.no.:		3740395
Revision date: 25.11.1998		



COPYRIGHT - This drawing is the property of Landia AS and cannot be shown, copied, given to a third party or used in any other way without permission from Landia AS.

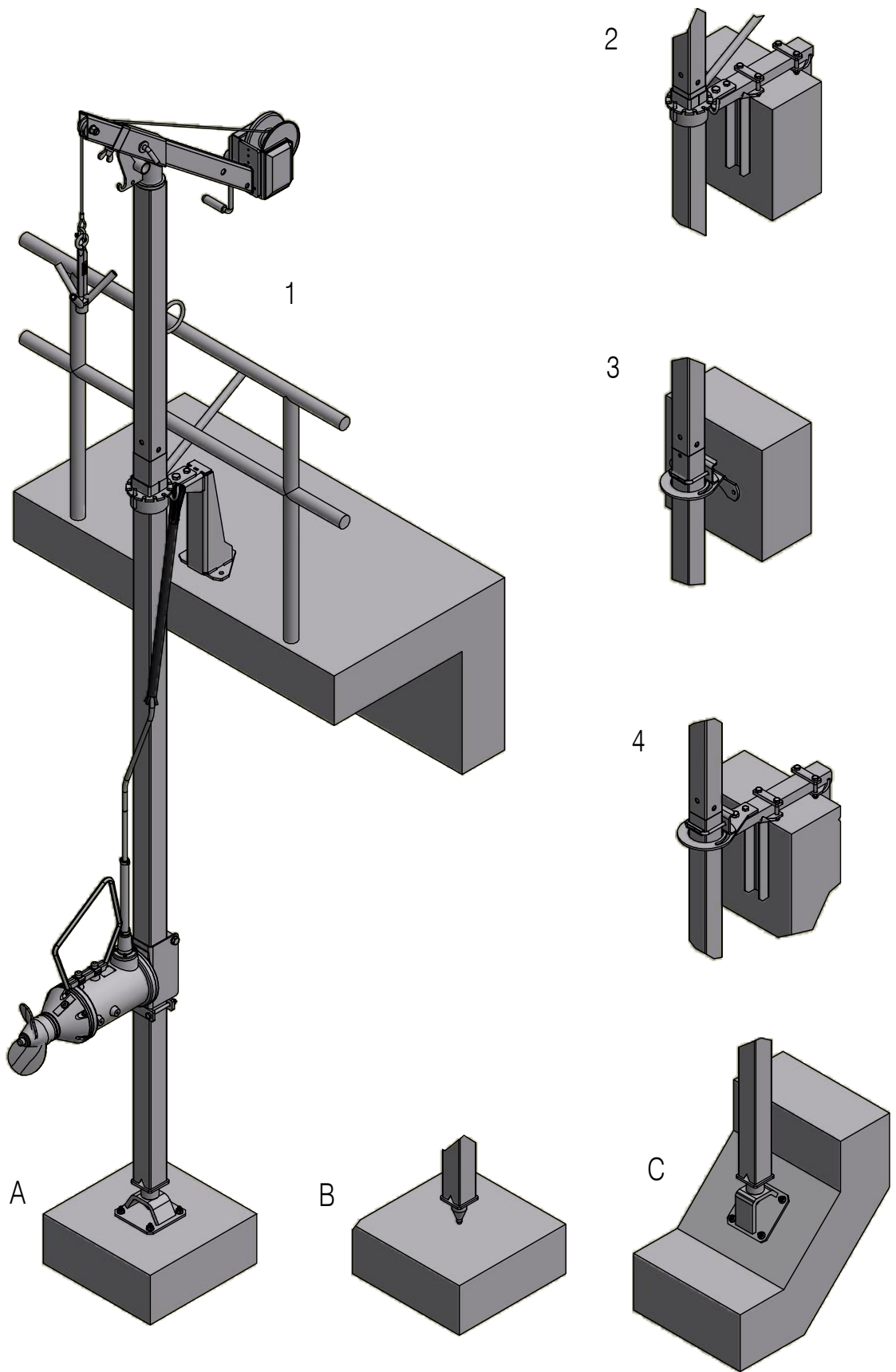

Styret dokument

**Landia**

POD-I/PODR-I ms. 100-132  
Betonbefæstelser, Concrete fixings  
Beton Befestigung, Fixation sur beton

Scale:	Sign.:	Date:
1 : 20	LBO   KSK	13-09-2017
Dwg.no.:	3740947	



COPYRIGHT - This drawing is the property of Landia AS and cannot be shown, copied, given to a third party or used in any other way without permission from Landia AS.

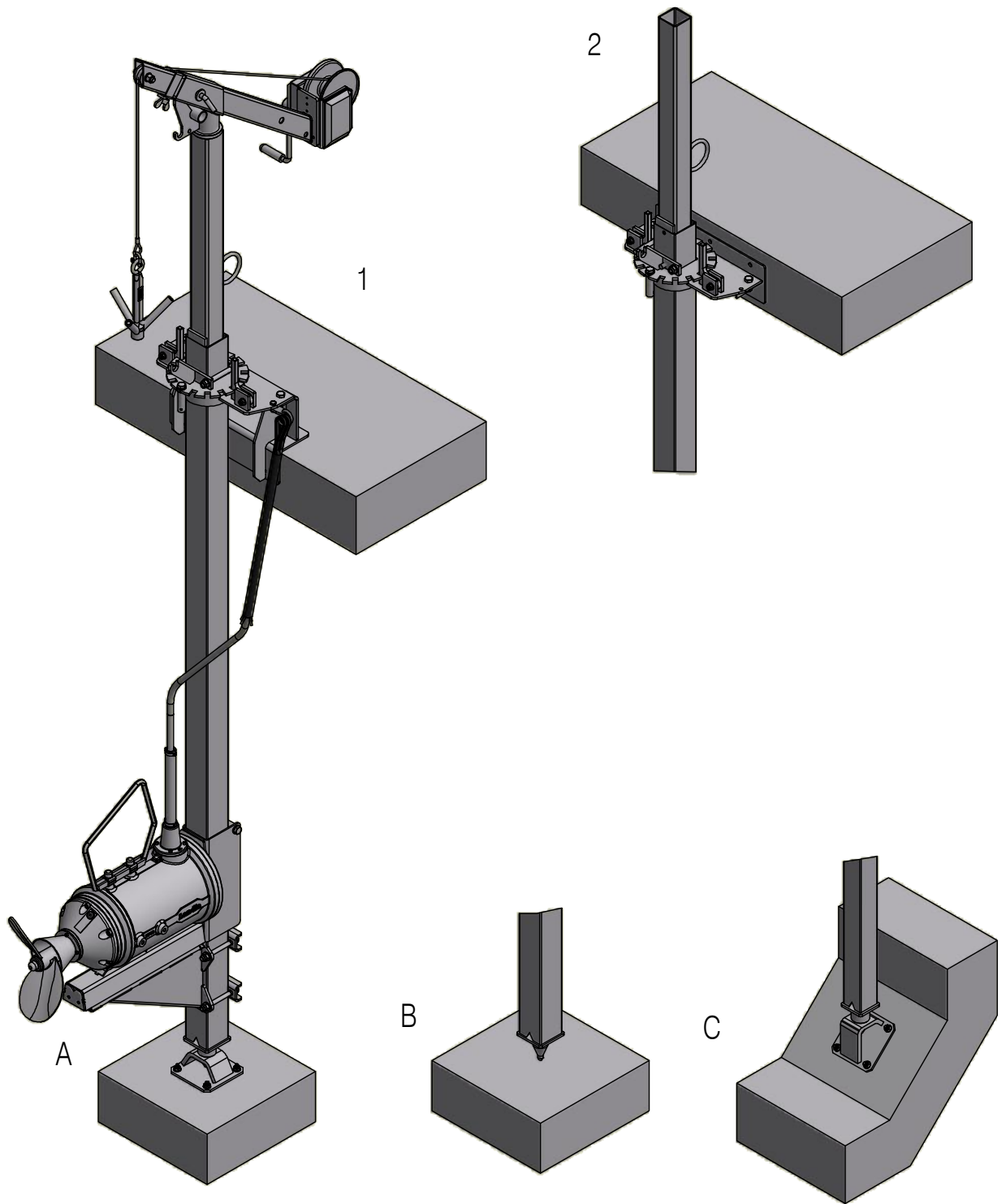

Styret dokument

**Landia**

POD-I/PODR-I ms.160  
Betonbefæstelser, Concrete fixings  
Beton Befestigung, Fixation sur beton

Scale:	Sign.:	Date:
1 : 20	LBO   KSK	14-09-2017
Dwg.no.:		3740949

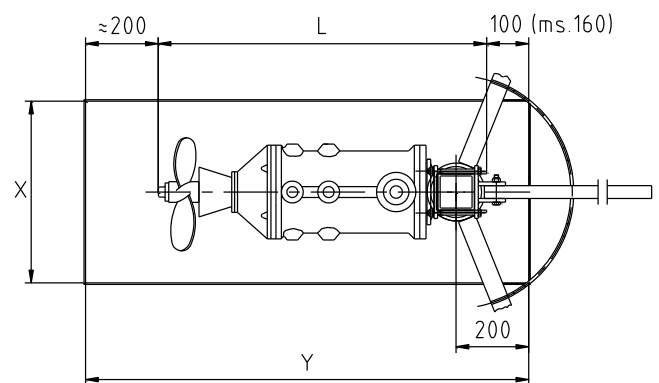
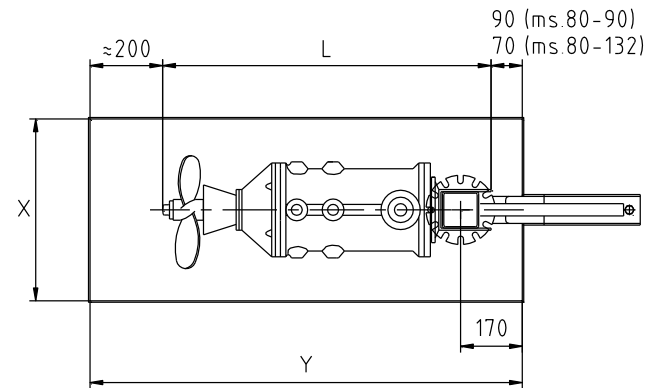
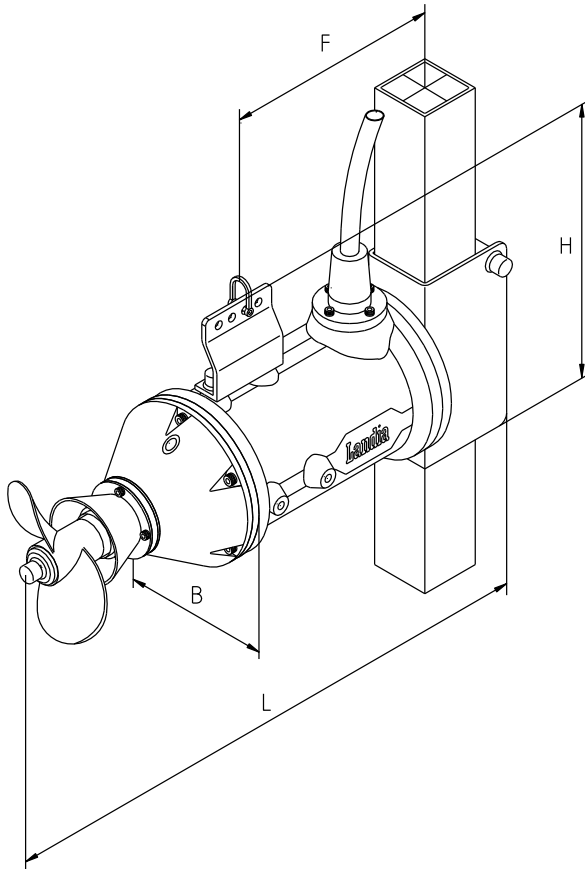
**POD-I IE1**

Varenr. Article no. Artikel Nr. Code no.	Effekt Power Leist. Puiss.	Serie Series Baureihe Série	Propel Propeller Propeller Hélice		H	B	L	F	Anbefalet mandehul Recommended man hole Empfohlenes Mannloch Trou d'homme recommandé
			[rpm]	dia [mm]					
1218396	0,55	80	750	∅190	280	173	550	190	300 x 850
1218397	0,75	90	750	∅220	295	189	555	-	300 x 850
1218398	1,1	100	750	∅270	382	213	690	285	350 x 950
1218301	1,5	100	750	∅290	382	213	690	240	350 x 950
1218302	2,2	112	750	∅330	338	226	725	265	400 x 1000
1218303	3,0	112	750	∅330	338	226	725	255	400 x 1000
1218304	4,0	132	750	∅355	555	264	830	-	400 x 1100
1218305	5,5	132	750	∅375	555	264	830	-	400 x 1100
1218307	7,5	160	750	∅385	601	318	910	315	450 x 1200
1214398	1,1	80	1500	∅170	280	173	550	-	300 x 850
1214302	2,2	90	1500	∅190	295	189	555	190	350 x 850
1214303	3,0	100	1500	∅220	382	213	690	-	350 x 950
1214304	4,0	100	1500	∅230	382	213	690	240	350 x 950
1214305	5,5	112	1500	∅260	338	226	725	-	400 x 1000
1214307	7,5	132	1500	∅250	555	264	830	295	400 x 1100
1214311	11,0	132	1500	∅275	555	264	830	295	400 x 1100
1214315	15,0	160	1500	∅310	601	318	910	325	450 x 1200
1214318	18,5	160	1500	∅325	601	318	910	330	450 x 1200

Ret til tekniske ændringer forbeholdes - We reserve the right to make technical alterations.  
 Technische und maßliche Änderungen vorbehalten - Sous réserve de modifications techniques.

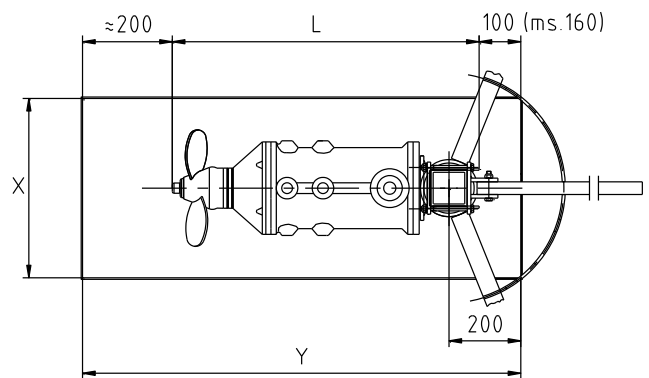
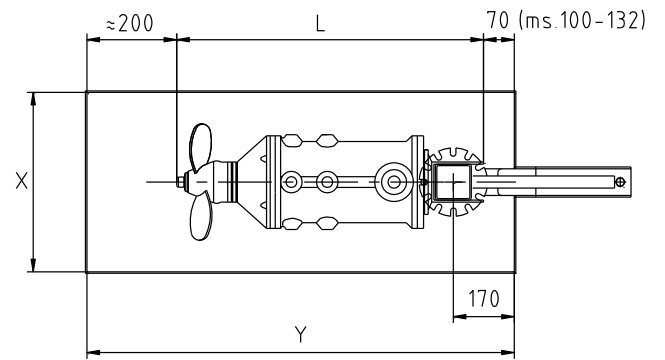
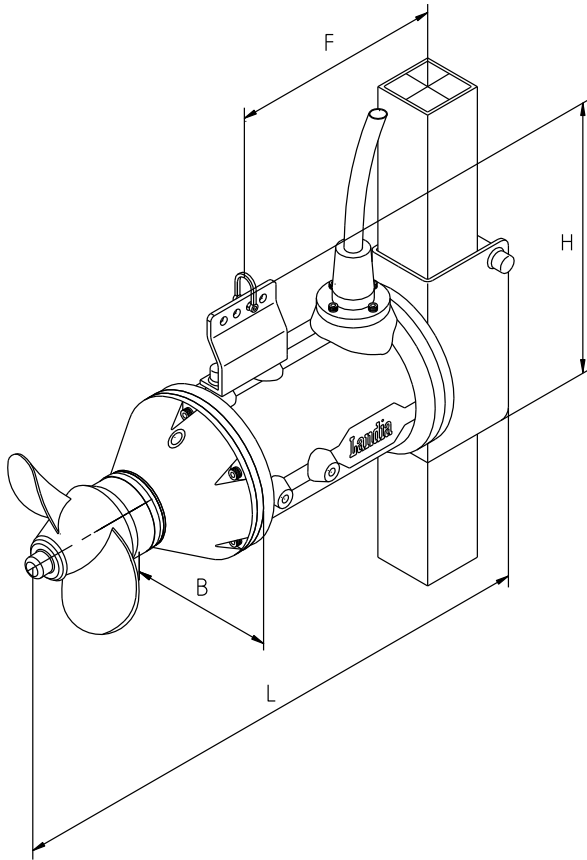
**POD-I IE2**

Varenr. Article no. Artikel Nr. Code no.	Effekt Power Leist. Puiss.	Serie Series Baureihe Série	Propel Propeller Propeller Hélice		H	B	L	F	Anbefalet mandehul Recommended man hole Empfohlenes Mannloch Trou d'homme recommandé
			[rpm]	dia [mm]					
1236301	1,1	100	1000	∅245	382	213	690	-	350 × 950
1236303	3,0/1,5	112	1000	∅320	338	226	725	-	400 × 1000
1236304	4,0	132	1000	∅335	555	264	830	-	400 × 1100
1236307	7,5/5,5	160	1000	∅380	601	318	910	-	450 × 1200

Ret til tekniske ændringer forbeholdes - We reserve the right to make technical alterations.  
 Technische und maßliche Änderungen vorbehalten - Sous réserve de modifications techniques.

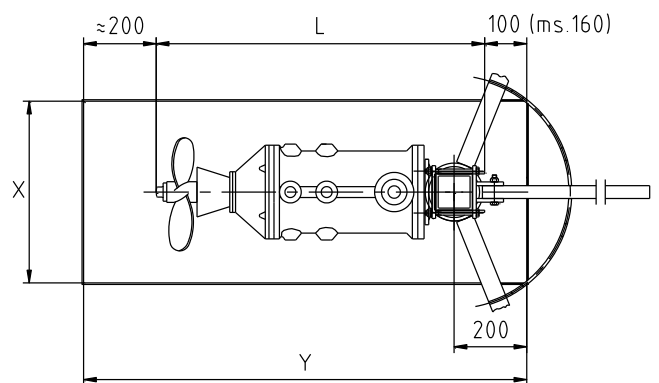
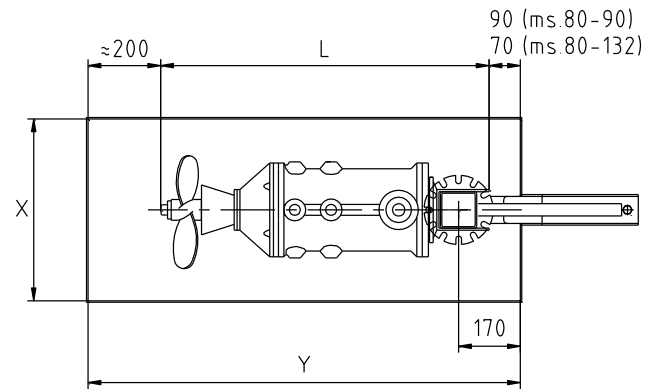
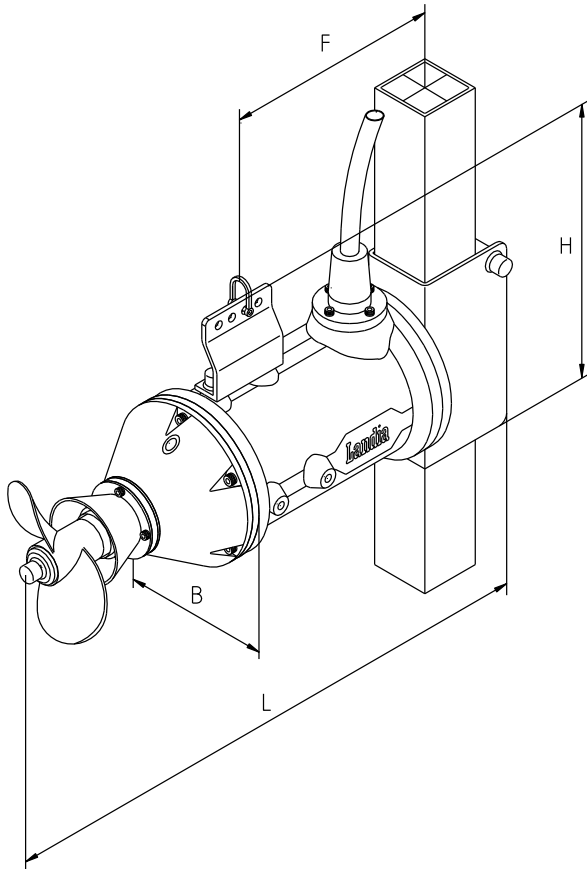
**PODR-I IE1**

Varenr. Article no. Artikel Nr. Code no.	Effekt Power Leist. Puiss.	Serie Series Baureihe Série	Propel Propeller0 Propeller Hélice		H	B	L	F	Anbefalet mandehul Recommended man hole Empfohlenes Mannloch Trou d'homme recommandé
			[rpm]	dia [mm]					
1218298	1,1	100R	750	ø270	382	213	690	205	350 x 950
1218201	1,5	100R	750	ø290	382	213	690	-	350 x 950
1218204	4,0	132R	750	ø355	555	264	830	290	400 x 1100
1218205	5,5	132R	750	ø375	555	264	830	290	400 x 1100
1218207	7,5	160R	750	ø385	601	318	910	-	450 x 1200
1214203	3,0	100R	1500	ø220	382	213	690	240	350 x 950
1214204	4,0	100R	1500	ø230	382	213	690	240	350 x 950
1214207	7,5	132R	1500	ø250	555	264	830	275	400 x 1100
1214211	11,0	132R	1500	ø275	555	264	830	270	400 x 1100
1214215	15,0	160R	1500	ø310	601	318	910	-	450 x 1250
1214218	18,5	160R	1500	ø325	601	318	910	-	450 x 1200

Ret til tekniske ændringer forbeholdes - We reserve the right to make technical alterations.  
 Technische und maßliche Änderungen vorbehalten - Sous réserve de modifications techniques.

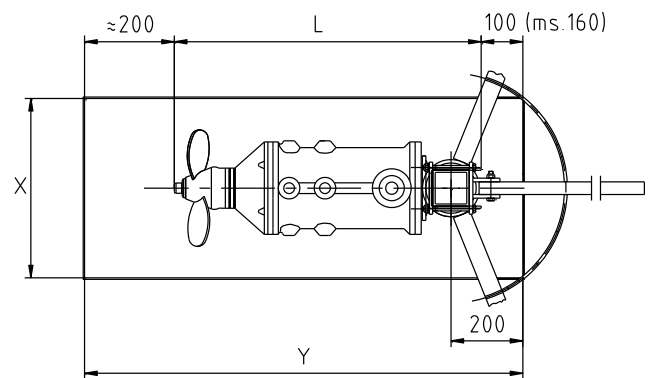
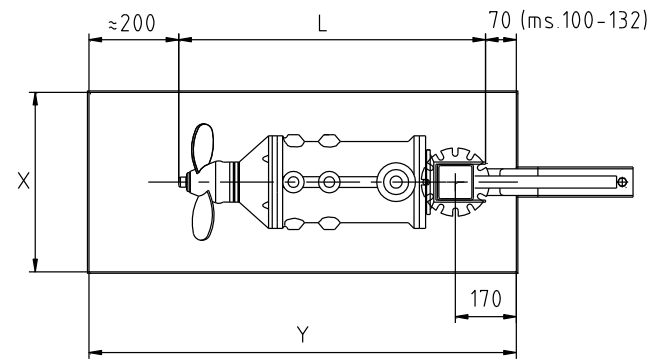
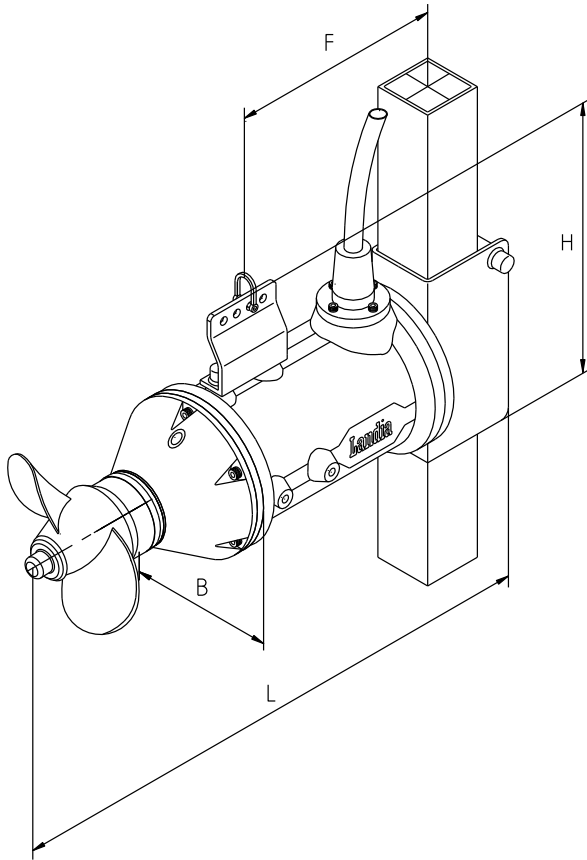
**PODR-I IE2**

Varenr. Article no. Artikel Nr. Code no.	Effekt Power Leist. Puiss.	Serie Series Baureihe Série	Propel Propeller Propeller Hélice		H	B	L	F	Anbefalet mandehul Recommended man hole Empfohlenes Mannloch Trou d'homme recommandé
			[rpm]	dia [mm]					
(400 V)	[kW]	ms.			[mm]	[mm]	[mm]	[mm]	
1236201	1,1	100R	1000	ø245	382	213	690	-	350 × 950
1236204	4,0	132R	1000	ø335	555	264	830	-	400 × 1100
1236207	7,5/5,5	160R	1000	ø380	601	318	910	-	450 × 1200

Ret til tekniske ændringer forbeholdes - We reserve the right to make technical alterations.  
 Technische und maßliche Änderungen vorbehalten - Sous réserve de modifications techniques.

# POD-I 1000

The POD-I is a compact submersible mixer for small tanks where the dry content matter is typically 1–4%

## APPLICATION EXAMPLES

- ▶ Selector tanks
- ▶ Anoxic and anaerobic tanks
- ▶ SBR reactors
- ▶ Pump wells
- ▶ Equalisation tanks

## PROPELLER RPM

1,000 rpm



## MATERIAL OF CONSTRUCTION

Motor housing and oil chamber	Cast iron EN-GJL-250
Propeller	Stainless steel W1.4301/AISI 304
Protection collar	Plastic PE-HD 1000
Shaft	W1.6582/AISI4340
Bolts	A4
Sealing set	Mechanical shaft seals: silicon carbide/silicon carbide
Oil type	15W-40 Vario HDX (with moisture detection)

## SERVICE AND MAINTENANCE

Recommended service interval/oil change	Maximum 2,500 operating hours/minimum once a year
Motor	Lifetime lubricated bearings
Oil chamber	Periodic oil change

## SURFACE TREATMENT

Machinery enamel: RAL 9005 (Jet Black)	Jet Black
2-component coating: RAL 7005 (Mouse Grey) (optional)	Mouse Grey

## ELECTRICAL CABLE

H07RN-F/S07RN-F EUCAFLEX<sup>Plus</sup> Cable.

Resistant to oil and UV radiation.



Number of conductors:

H07RN-F 7G1.5 mm<sup>2</sup> (Not used in United Kingdom)

H07RN-F 7G2,5 mm<sup>2</sup> (Only United Kingdom. Motor ≤ 5,5 kW)

S07RN-F 7G4+3x1.5 mm<sup>2</sup>

As standard supplied with 7 m of cable (extra length available upon request).

## MONITORING FUNCTIONS

Bimetal thermal sensors 120 °C

Moisture detection system (optional)

## DESIGN

The Landia POD-I is a compact, direct drive mixer. The propeller speed is the same as the motor speed. It has a self-cleaning propeller and a sealing system consisting of two mechanical shaft seals.

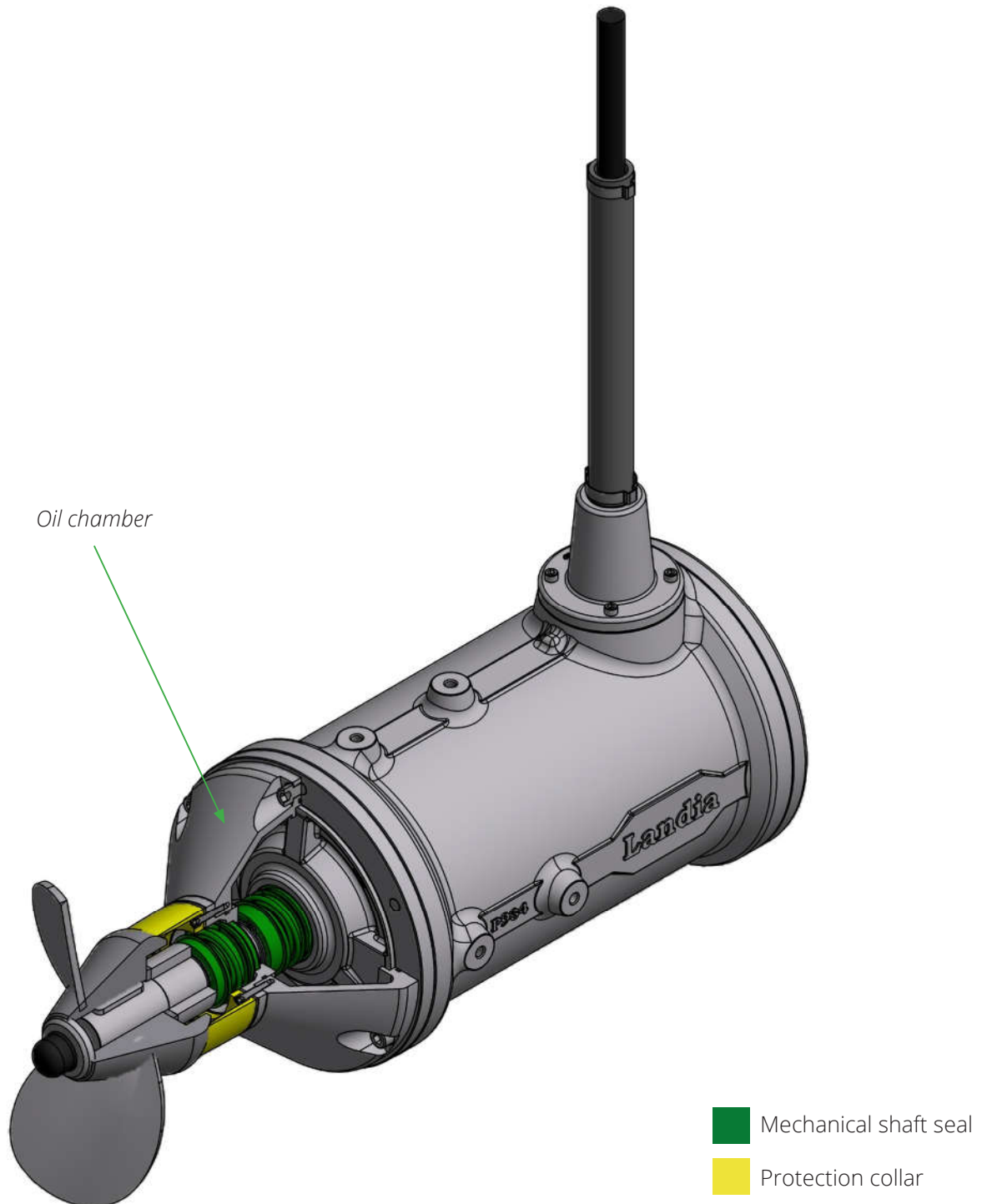



**ELECTRICAL DATA**

Motor type	3-phase AC motor
Nominal voltage	400 V
Minimum voltage allowed	360 V
Nominal frequency	50 Hz
Applicable for VFD operation	Yes
Ingress protection rating	IP 68
Insulation class	F
ATEX classification	II 2 G Ex db h IIB T4 Gb (Option, only available for specific models)

Model	Item number	Nominal power	Motor	Full load current (400 V)	Connection method	Start current (DOL)	cos phi	Efficiency
		[kW]	[rpm]	[A]	Y/Δ	[A]		[%]
POD-I 1.1 kW-1,000 rpm IE2	1236301	1.1	955	2.75	Y	15	0.71	78.1
POD-I 3.0/1.5 kW-1,000 rpm IE2	1236303	3.0	955	7.1	Δ	50	0.73	83.3
POD-I 4.0 kW-1,000 rpm IE2	1236304	4.0	965	8.5	Δ	43	0.79	85.5
POD-I 7.5/5.5 kW-1,000 rpm IE2	1236307	7.5	970	15.5	Δ	91	0.79	87.5

For voltages others than 400 V/50 Hz please refer to the attached Appendix.

## OVERALL DIMENSIONS

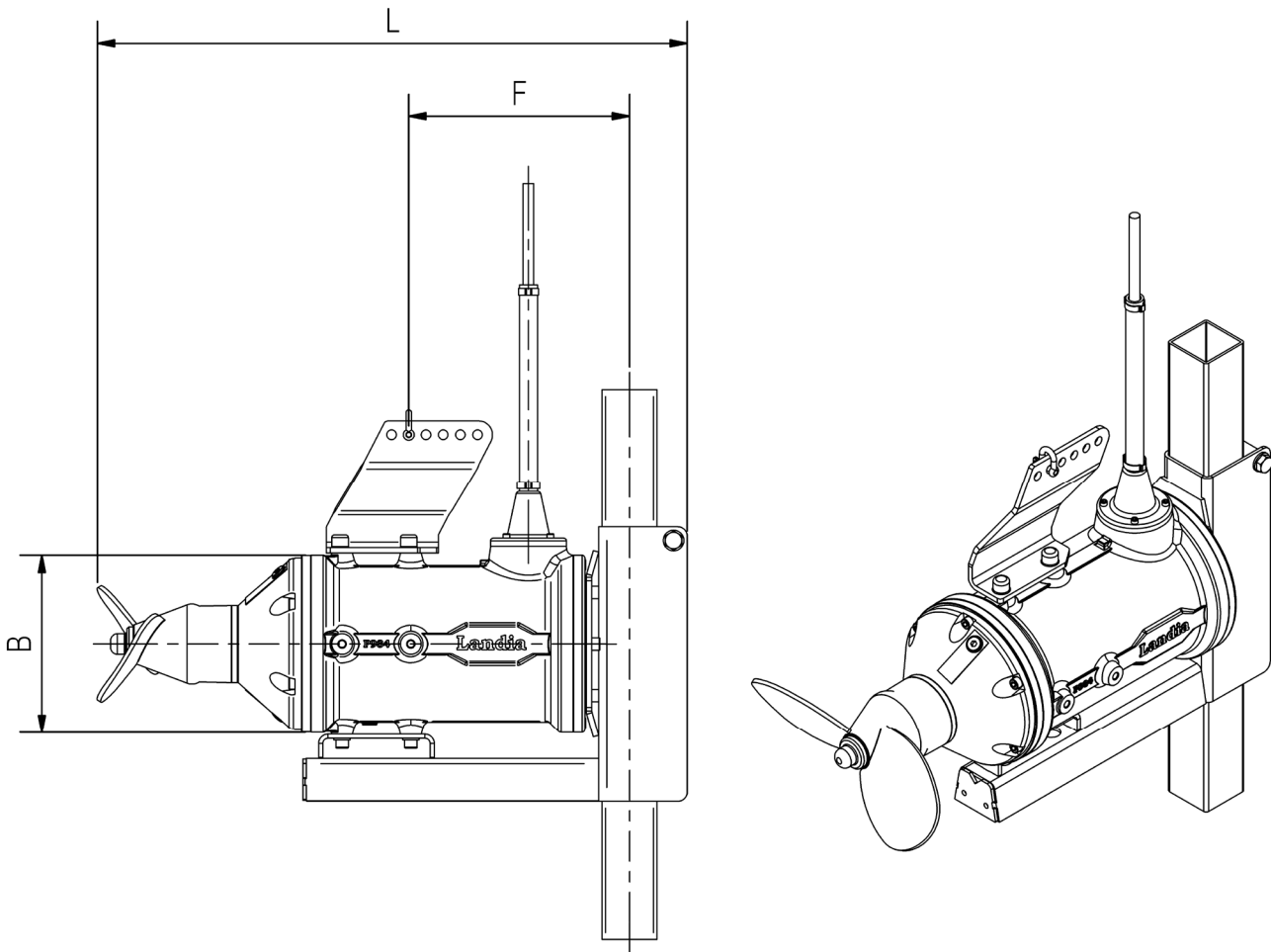

Model	Item number	Propeller diameter [mm]	B [mm]	F [mm]	L [mm]	Guide pipe [mm]	Weight [kg]
POD-I 1.1 kW-1,000 rpm IE2	1236301	ø245	213	-	690	80x80	80
POD-I 3.0/1.5 kW-1,000 rpm IE2	1236303	ø265	226	-	725	80x80	90
POD-I 3.0/1.5 kW-1,000 rpm IE2	1236303	ø290	226	-	725	80x80	90
POD-I 3.0/1.5 kW-1,000 rpm IE2	1236303	ø320	226	-	725	80x80	90
POD-I 4.0 kW-1,000 rpm IE2	1236304	ø335	264	-	830	80x80	110
POD-I 7.5/5.5 kW-1,000 rpm IE2	1236307	ø365	318	-	910	100x100	185
POD-I 7.5/5.5 kW-1,000 rpm IE2	1236307	ø380	318	-	910	100x100	185

We reserve the right to make technical changes.

# POD-I 1500

The POD-I is a compact submersible mixer for smaller tanks where the dry matter content is typically 1–4%.

## APPLICATION EXAMPLES

- ▶ Selector tanks
- ▶ Anoxic and anaerobic tanks
- ▶ SBR reactors
- ▶ Pump wells
- ▶ Equalisation tanks



## PROPELLER RPM

1,500 rpm

## MATERIAL OF CONSTRUCTION

Motor housing and oil chamber	Cast iron EN-GJL-250
Propeller and protection collar	Steel W1.0038/S235JR Stainless steel W1.4301/AISI 304 (optional)
Shaft	W1.6582/AISI4340
Bolts	A4
Sealing set	Mechanical shaft seals: silicon carbide/silicon carbide
Oil type	15W-40 Vario HDX (with moisture detection)

## SERVICE AND MAINTENANCE

Recommended service interval/oil change	Maximum 2,500 operating hours/minimum once a year
Motor	Lifetime lubricated bearings
Oil chamber	Periodic oil change

## SURFACE TREATMENT

Machinery enamel: RAL 9005 (Jet Black)	Jet Black
2-component coating: RAL 7005 (Mouse Grey) (optional)	Mouse Grey

## ELECTRICAL CABLE

H07RN-F/S07RN-F EUCAFLEX<sup>Plus</sup> Cable.

Resistant to oil and UV radiation.



Number of conductors:

H07RN-F 7G1.5 mm<sup>2</sup> (Not used in United Kingdom)

H07RN-F 7G2,5 mm<sup>2</sup> (Only United Kingdom. Motor ≤ 5,5 kW)

S07RN-F 7G4+3x1.5 mm<sup>2</sup>

As standard supplied with 7 m of cable (extra length available upon request).

## MONITORING FUNCTIONS

Bimetal thermal sensors 120 °C

Moisture detection system (optional)

## DESIGN

The Landia POD-I is a compact, direct drive mixer. The propeller speed is the same as the motor speed. It has self-cleaning stainless propellers and a sealing system consisting of two mechanical shaft seals.

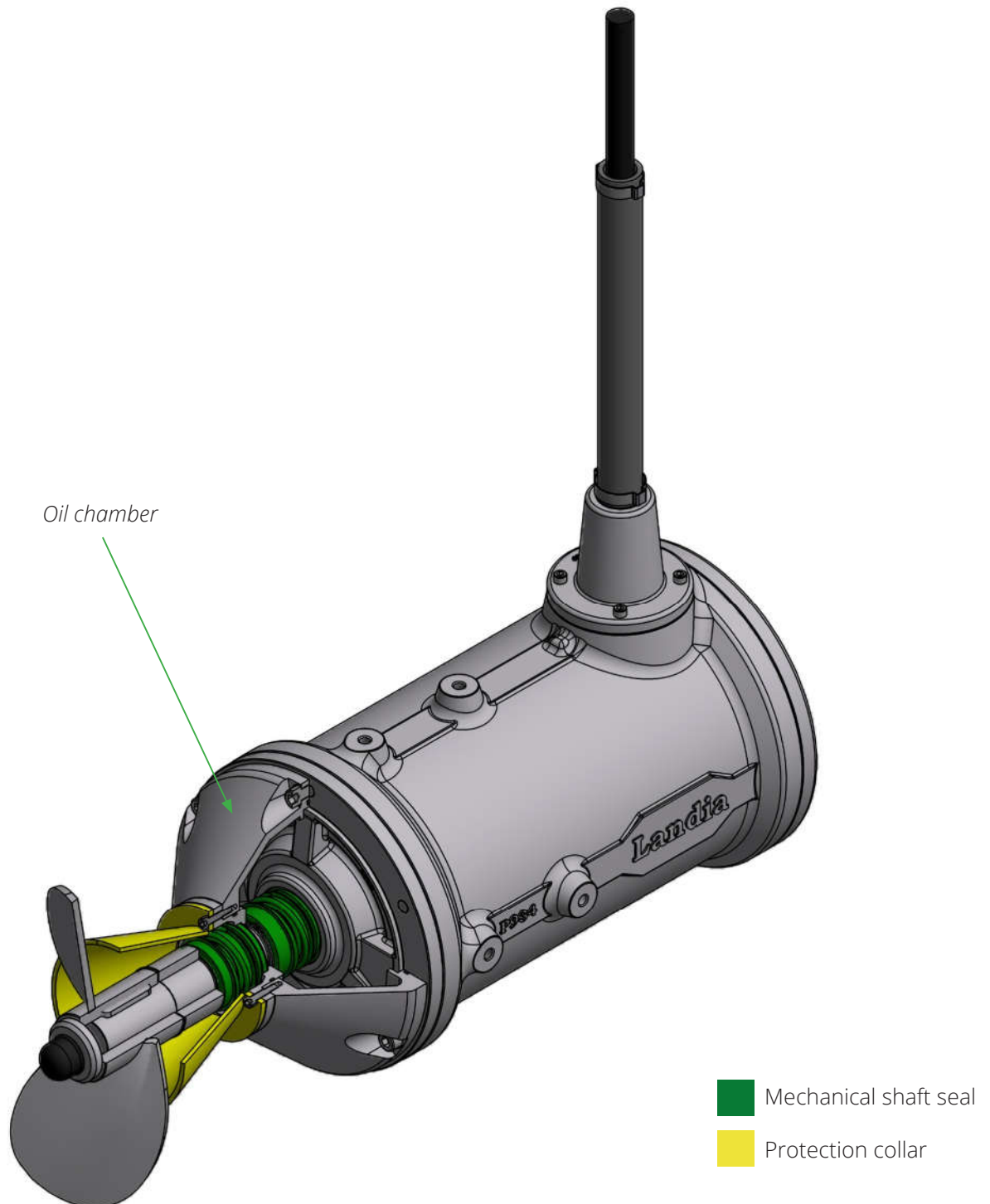

**ELECTRICAL DATA**

Motor type	3-phase AC motor
Nominal voltage	400 V
Minimum voltage allowed	360 V
Nominal frequency	50 Hz
Applicable for VFD operation	Yes
Ingress protection rating	IP 68
Insulation class	F
ATEX classification	II 2 G Ex db h IIB T4 Gb (Option, only available for specific models)

Model	Item number	Nominal power	Motor	Full load current (400 V)	Connection method	Start current (DOL)	cos phi	Efficiency
		[kW]	[rpm]	[A]	Y/Δ	[A]		[%]
POD-I 1.1 kW-1,500 rpm	1214398	1.1	1,410	2.6	Y	14	0.79	76.7
POD-I 2.2 kW-1,500 rpm	1214302	2.2	1,410	5.0	Y	30	0.80	80.2
POD-I 3.0 kW-1,500 rpm	1214303	3.0	1,430	6.7	Δ	43	0.79	82.4
POD-I 4.0 kW-1,500 rpm	1214304	4.0	1,435	8.8	Δ	61	0.78	84.1
POD-I 5.5 kW-1,500 rpm	1214305	5.5	1,440	11.0	Δ	68	0.87	84.6
POD-I 7.5 kW-1,500 rpm	1214307	7.5	1,455	15.0	Δ	90	0.83	86.2
POD-I 11.0 kW-1,500 rpm	1214311	11.0	1,455	21.5	Δ	146	0.84	87.9
POD-I 15.0 kW-1,500 rpm	1214315	15.0	1,465	29.0	Δ	212	0.84	88.7
POD-I 18.5 kW-1,500 rpm	1214318	18.5	1,460	35.0	Δ	238	0.85	89.3

For voltages others than 400 V/50 Hz please refer to the attached Appendix.

## OVERALL DIMENSIONS

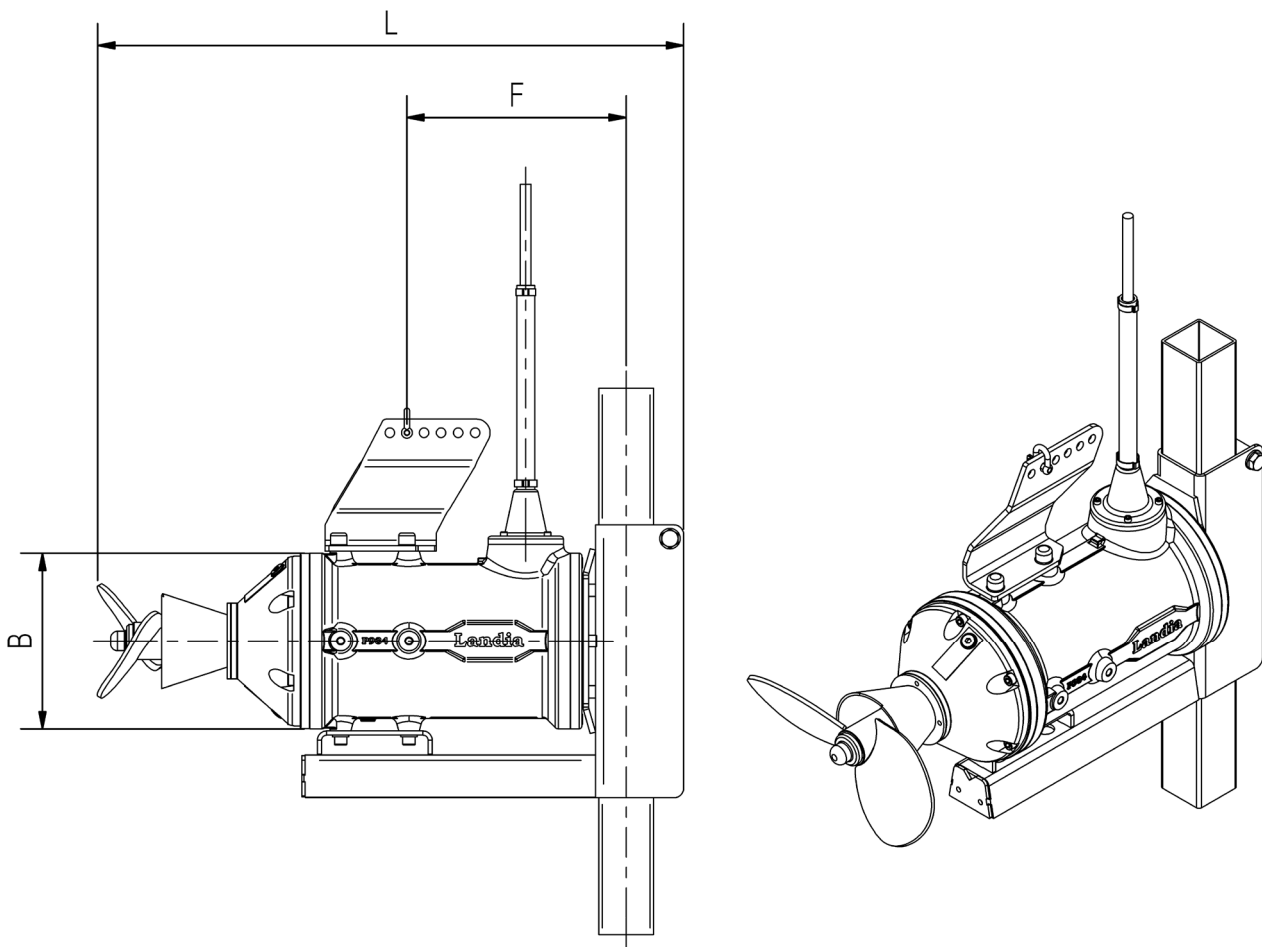

Model	Item number	Propeller diameter [mm]	B [mm]	F [mm]	L [mm]	Guide pipe [mm]	Weight [kg]
POD-I 1.1 kW-1,500 rpm	1214398	ø170	173	-	505	60x60	31
POD-I 2.2 kW-1,500 rpm	1214302	ø190	189	190	555	60x60	38
POD-I 3.0 kW-1,500 rpm	1214303	ø220	213	240	690	80x80	58
POD-I 4.0 kW-1,500 rpm	1214304	ø230	213	240	690	80x80	62
POD-I 5.5 kW-1,500 rpm	1214305	ø260	226	-	725	80x80	70
POD-I 7.5 kW-1,500 rpm	1214307	ø250	264	295	830	80x80	112
POD-I 11.0 kW-1,500 rpm	1214311	ø275	264	295	830	80x80	119
POD-I 15.0 kW-1,500 rpm	1214315	ø310	318	325	910	80x80	148
POD-I 18.5 kW-1,500 rpm	1214318	ø325	318	330	910	80x80	177

We reserve the right to make technical changes.

# PODR-I 1000

The PODR-I is a compact submersible mixer for smaller tanks where the dry content matter is typically 1–4%.

## APPLICATION EXAMPLES

- Selector tanks
- Anoxic and anaerobic tanks
- SBR reactors
- Pump wells
- Equalisation tanks



## PROPELLER RPM

1,000 rpm

## MATERIAL OF CONSTRUCTION

Motor housing and oil chamber	W1.4404/AISI316
Propeller	Stainless steel W1.4301/AISI 304
Protection collar	Plastic PE-HD 1000
Shaft	W1.4404/AISI316
Bolts	A4
Sealing set	Mechanical shaft seals: silicon carbide/silicon carbide
Oil type	15W-40 Vario HDX (with moisture detection)



## SERVICE AND MAINTENANCE

Recommended service interval/oil change	Maximum 2,500 operating hours/minimum once a year
Motor	Lifetime lubricated bearings
Oil chamber	Periodic oil change

## ELECTRICAL CABLE

H07RN-F/S07RN-F EUCAFLEX<sup>Plus</sup> Cable.

Resistant to oil and UV radiation.

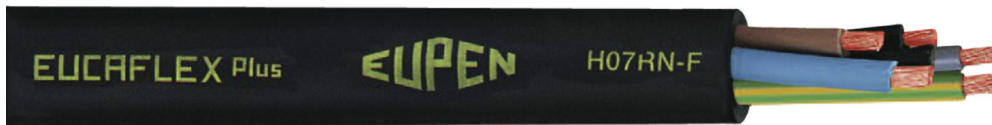

Number of conductors:

H07RN-F 7G1.5 mm<sup>2</sup> (Not used in United Kingdom)

H07RN-F 7G2,5 mm<sup>2</sup> (Only United Kingdom. Motor ≤ 5,5 kW)

S07RN-F 7G4+3x1.5 mm<sup>2</sup>

As standard supplied with 7 m of cable (extra length available upon request).

## MONITORING FUNCTIONS

Bimetal thermal sensors 120 °C

Moisture detection system (optional)

## DESIGN

The Landia PODR-I is a compact, direct drive mixer. The propeller speed is the same as the motor speed. It has a self-cleaning stainless propeller and a sealing system consisting of two mechanical shaft seals.

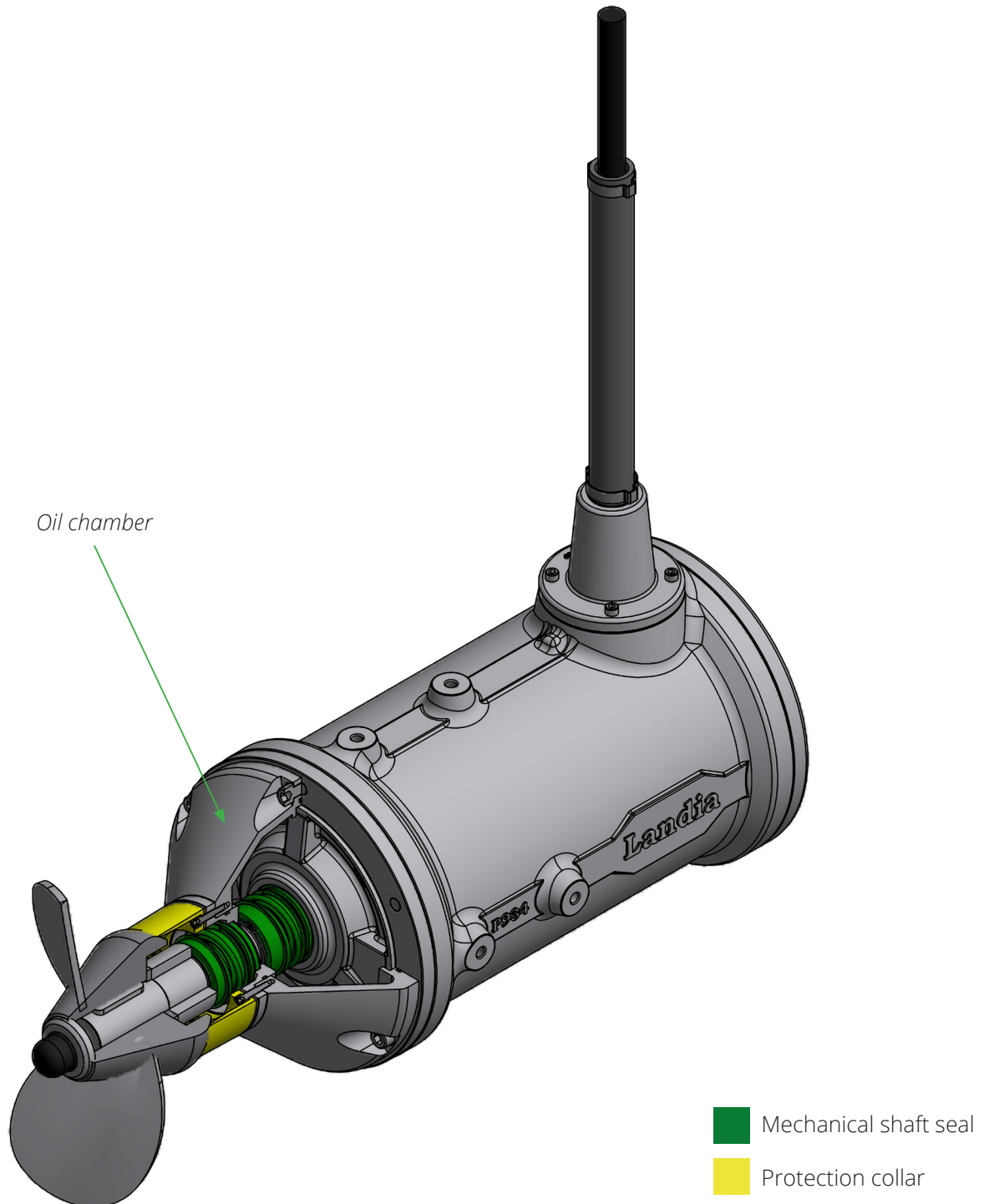

**ELECTRICAL DATA**

Motor type	3-phase AC motor
Nominal voltage	400 V
Minimum voltage allowed	360 V
Nominal frequency	50 Hz
Applicable for VFD operation	Yes
Ingress protection rating	IP 68
Insulation class	F
ATEX classificatio	Not possible

Model	Item number	Nominal power	Motor	Full load current (400 V)	Connection method	Start current (DOL)	cos phi	Efficiency
		[kW]	[rpm]	[A]	Y/Δ	[A]		[%]
PODR-I 1.1 kW-1,000 rpm IE2	1236201	1.1	955	2.75	Y	15	0.71	78.1
PODR-I 4.0 kW-1,000 rpm IE2	1236204	4.0	965	8.5	Δ	43	0.79	85.5
PODR-I 7.5/5.5 kW-1,000 rpm IE2	1236207	7.5	970	15.5	Δ	91	0.79	87.5

For voltages others than 400 V/50 Hz please refer to the attached Appendix.

## OVERALL DIMENSIONS

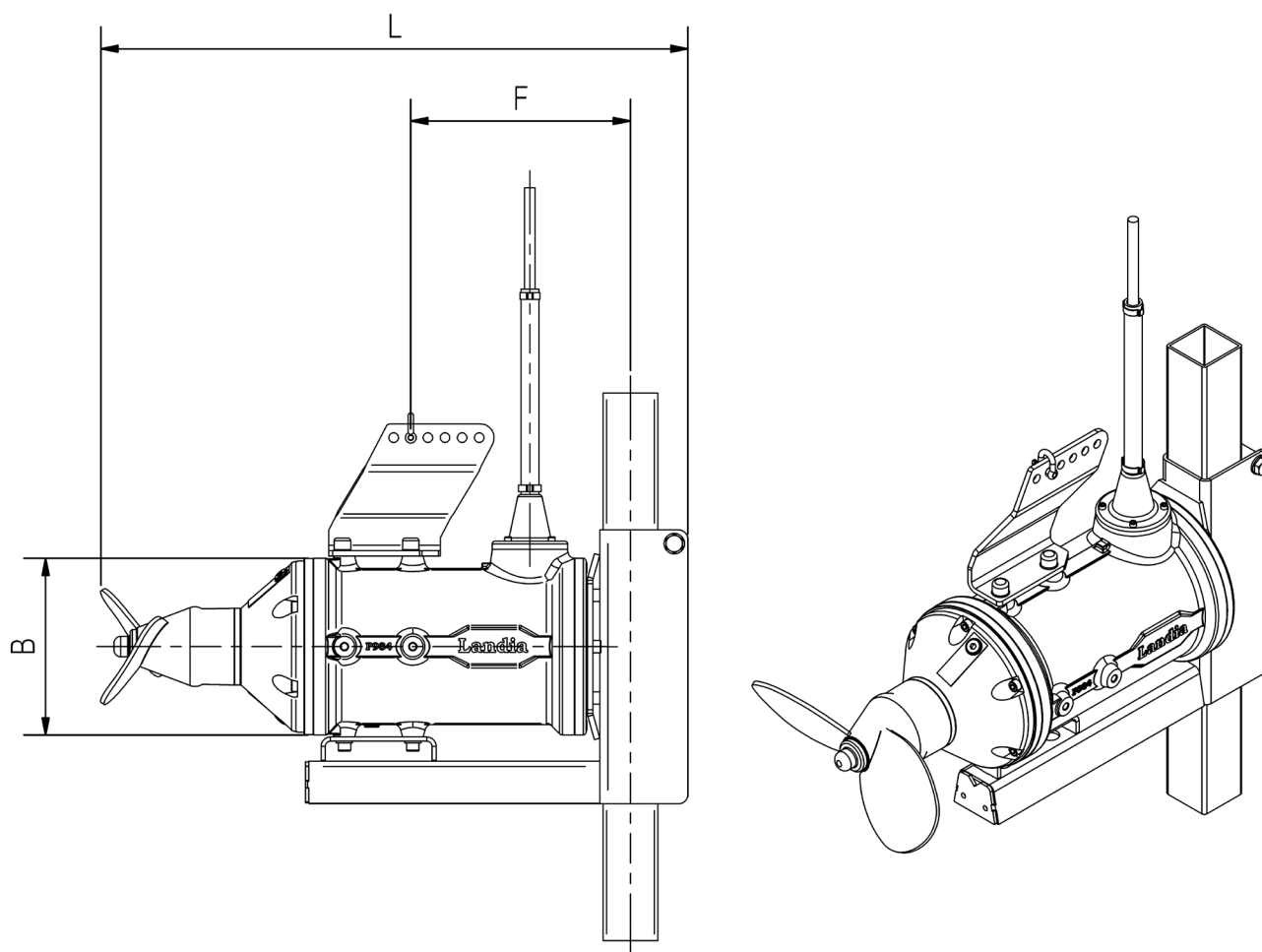

Model	Item number	Propeller diameter [mm]	B [mm]	F [mm]	L [mm]	Guide pipe [mm]	Weight [kg]
PODR-I 1.1 kW-1,000 rpm IE2	1236201	ø245	213	-	690	80x80	80
PODR-I 4.0 kW-1,000 rpm IE2	1236204	ø335	264	-	830	80x80	110
PODR-I 7.5/5.5 kW-1,000 rpm IE2	1236207	ø365	318	-	910	100x100	185

We reserve the right to make technical changes.

# PODR-I 1500

The PODR-I is a compact submersible mixer for smaller tanks where the dry matter content is typically 1–4%.

## APPLICATION EXAMPLES

- Selector tanks
- Anoxic and anaerobic tanks
- SBR reactors
- Pump wells
- Equalisation tanks

## PROPELLER RPM

1,500 rpm



## MATERIAL OF CONSTRUCTION

Motor housing and oil chamber	W1.4404/AISI316
Propeller and protection collar	Stainless steel W1.4301/AISI 304 (optional)
Shaft	W1.4404/AISI316
Bolts	A4
Sealing set	Mechanical shaft seals: silicon carbide/silicon carbide
Oil type	15W-40 Vario HDX (with moisture detection)

## SERVICE AND MAINTENANCE

Recommended service interval/oil change	Maximum 2,500 operating hours/minimum once a year
Motor	Lifetime lubricated bearings
Oil chamber	Periodic oil change

## ELECTRICAL CABLE

H07RN-F/S07RN-F EUCAFLEX<sup>Plus</sup> Cable.

Resistant to oil and UV radiation.



Number of conductors:

H07RN-F 7G1.5 mm<sup>2</sup> (Not used in United Kingdom)

H07RN-F 7G2.5 mm<sup>2</sup> (Only United Kingdom. Motor ≤ 5,5 kW)

S07RN-F 7G4+3x1.5 mm<sup>2</sup>

As standard supplied with 7 m of cable (extra length available upon request).

## MONITORING FUNCTIONS

Bimetal thermal sensors 120 °C

Moisture detection system (optional)

## DESIGN

The Landia PODR-I is a compact, direct drive mixer. The propeller speed is the same as the motor speed. It has self-cleaning stainless propellers and a sealing system consisting of two mechanical shaft seals.

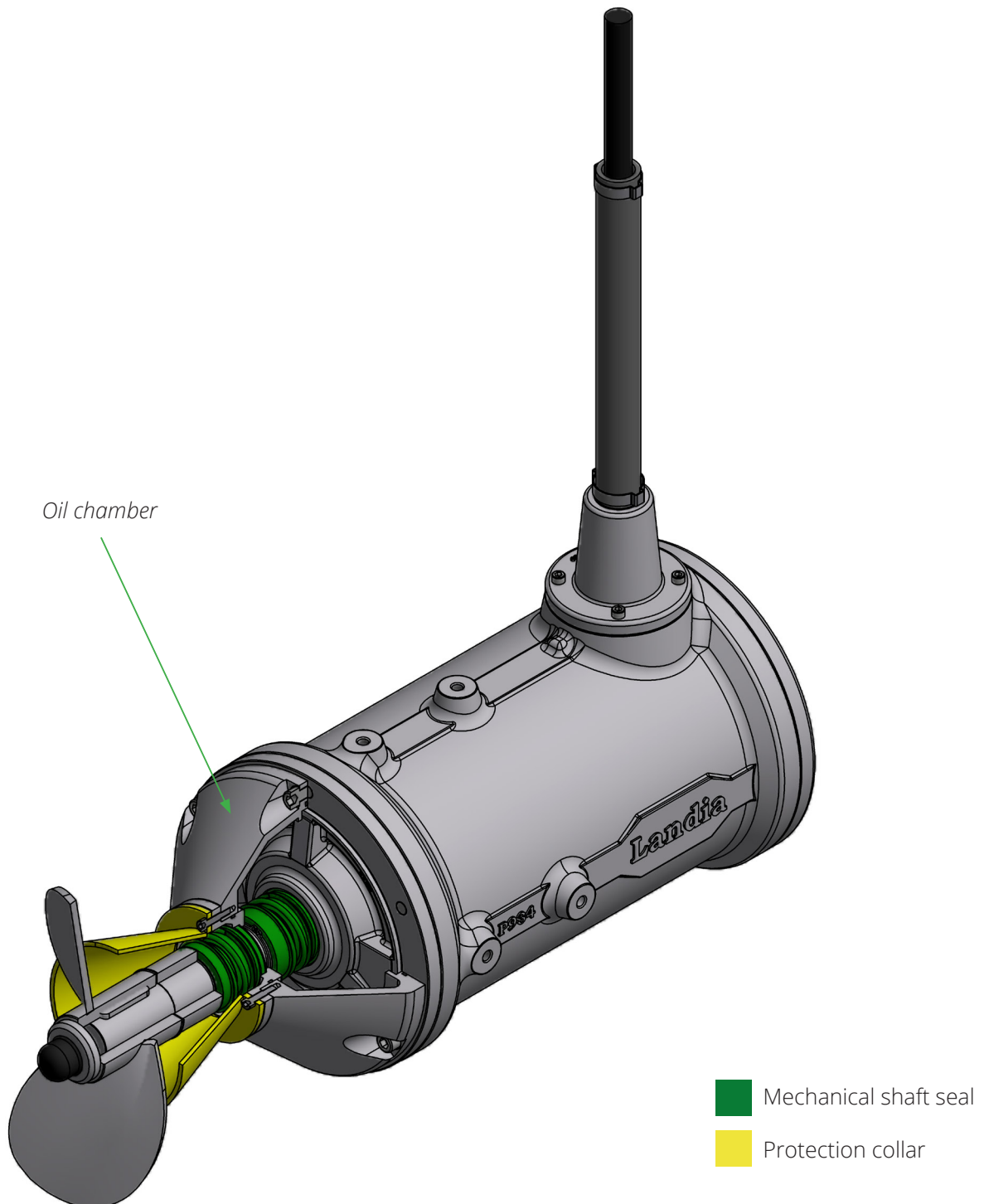

**ELECTRICAL DATA**

Motor type	3-phase AC motor
Nominal voltage	400 V
Minimum voltage allowed	360 V
Nominal frequency	50 Hz
Applicable for VFD operation	Yes
Ingress protection rating	IP 68
Insulation class	F
ATEX classification	Not possible

Model	Item number	Nominal power	Motor	Full load current (400 V)	Connection method	Start current (DOL)	cos phi	Efficiency
		[kW]	[rpm]	[A]	Y/Δ	[A]		[%]
PODR-I 3.0 kW-1,500 rpm	1214203	3.0	1,430	6.7	Δ	43	0.79	82.4
PODR-I 4.0 kW-1,500 rpm	1214204	4.0	1,435	8.8	Δ	61	0.78	84.1
PODR-I 7.5 kW-1,500 rpm	1214207	7.5	1,455	15.0	Δ	90	0.83	86.2
PODR-I 11.0 kW-1,500 rpm	1214211	11.0	1,455	21.5	Δ	146	0.84	87.9
PODR-I 15.0 kW-1,500 rpm	1214215	15.0	1,465	29.0	Δ	212	0.84	88.7
PODR-I 18.5 kW-1,500 rpm	1214218	18.5	1,460	35.0	Δ	238	0.85	89.3

For voltages others than 400 V/50 Hz please refer to the attached Appendix.



## OVERALL DIMENSIONS

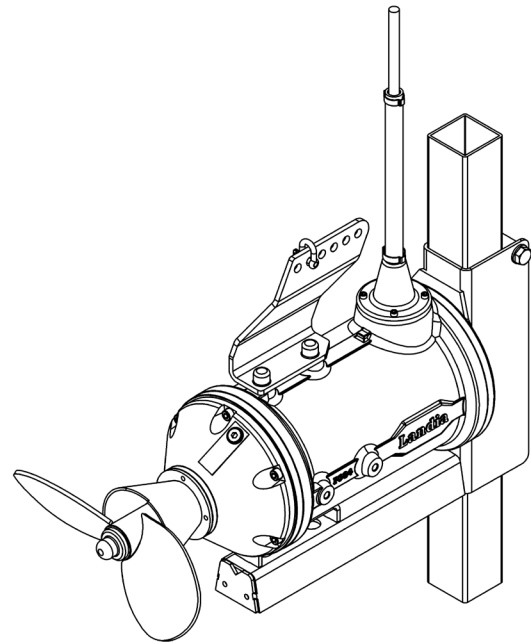
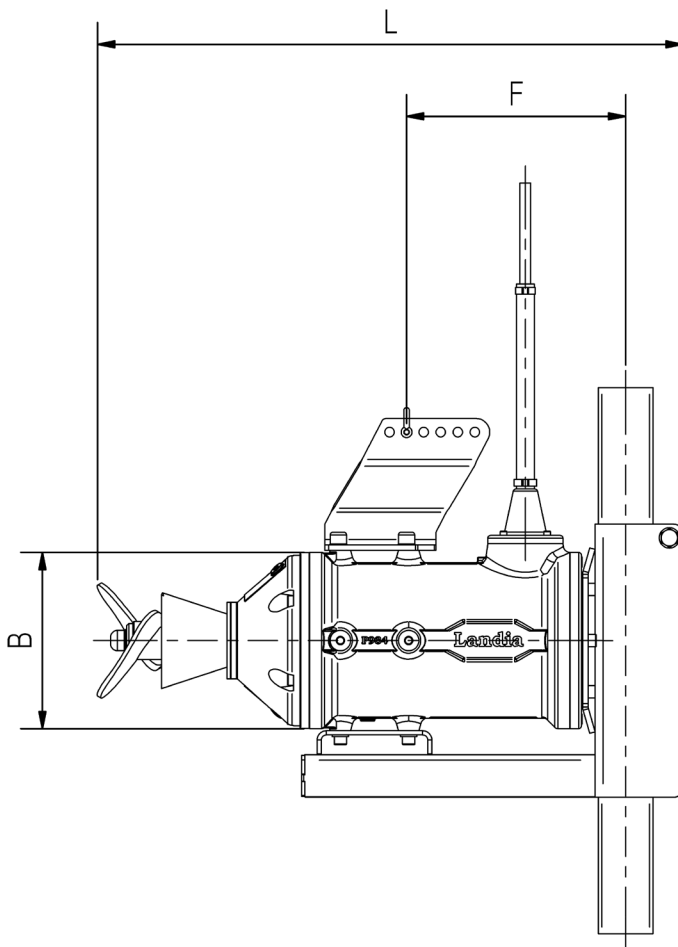

Model	Item number	Propeller diameter [mm]	B [mm]	F [mm]	L [mm]	Guide pipe [mm]	Weight [kg]
PODR-I 3.0 kW-1,500 rpm	1214203	ø220	213	240	690	80x80	58
PODR-I 4.0 kW-1,500 rpm	1214204	ø230	213	240	690	80x80	62
PODR-I 7.5 kW-1,500 rpm	1214207	ø250	264	295	830	80x80	115
PODR-I 11.0 kW-1,500 rpm	1214211	ø275	264	295	830	80x80	125
PODR-I 15.0 kW-1,500 rpm	1214215	ø310	318	325	910	80x80	148
PODR-I 18.5 kW-1,500 rpm	1214218	ø325	318	330	910	80x80	182

We reserve the right to make technical changes.

## Table of contents

Introduction .....	2
Application.....	2
Warning.....	2
Service/repair .....	2
Rating plate .....	3
Power connection.....	3
Operation .....	3
Capacity .....	4
Inspection.....	4
Oil control .....	4
Equipment .....	4
Disassembling/assembling the unit.....	4

## Introduction

POD-I is a horizontal submersible mixer.

The unit is placed in the cross section of the liquid to obtain the required mixing.

During operation, the mixer is locked by the guide pipe to obtain stability.

The mixing takes place by means of an electric motor; a propeller is installed on the motor shaft.

The oil filled oil chamber between motor and propeller provides cooling and lubrication of the mechanical seals.

The sealing system consists of two mechanical seals. The exterior seal separates the medium from the oil chamber; the interior seal separates the oil from the motor casing.

The following pages describe the connection and the maintenance of mixers type POD-I.

## Application

This mixer is to be used for flow creation, mixing and homogenization of liquids with a high or low dry matter content, like e.g. wastewater, sludge and paper pulp, as well as chemical liquids and manure. The mixer can be placed in square and circular tanks and is to be applied only fully submerged below liquid level.

If the mixer is to be applied for other purposes, contact Landia A/S for advice.

## Warning

please note the following points:

- Only a certified electrician is allowed to connect the unit.
- Prior to installation and commissioning ensure that the equipment is installed correctly and fixed to the mixer, as well as ensure that the equipment in the tank is fixed safely.
- Prior to the first start of the mixer, the propeller shaft must be rotated manually. This also applies if the mixer has not been in operation for a longer period.
- The electrical cable is always to be tightened by means of the chain to prevent the cable from getting into contact with the propeller. If the mixer is not supplied with a chain, the cable is to be protected against damage in another way, e.g. by means of a cable mesh.
- It must be ensured that the propeller cannot touch the tank.
- It is always to be ensured that the mixer is fully below liquid level during operation.
- Prior to hoisting the mixer at service/repair it is always to be ensured that the electrical connection of the mixer is switched off or locked. Prior to service/repair the mixer should be cleaned thoroughly.
- When the mixer is hoisted or lowered, its cable and chain are always to be placed outside the work area.
- For service/repair of mixers installed in well/tank with explosion danger/toxic gases we refer to the national safety directions as far as safety is concerned, e.g. concerning the toxic hydrogen sulphide.

## Service/repair

To maintain a high operating safety and a long service life without unnecessary and expensive repair it is important from the beginning to execute regular and preventive service. Maintenance should be executed according to the intervals stated in the manual. The instructions should always be followed carefully and only apply the parts described by Landia A/S in the spare parts list.

If you do not want to execute the service yourself - we can offer you a service agreement - please call for further information.

### Please note

If spare parts not identical to the recommended are applied at service/repair, the guarantee from Landia A/S will be annulled. Spare parts can be ordered at Landia A/S or your local distributor.

For major repairs at a special workshop please contact:

Head Office:  
LANDIA A/S  
Industrivej 2  
DK-6940 Lem St.  
Tel.: +45 97 341244  
[info@landia.dk](mailto:info@landia.dk)  
[www.landia.dk](http://www.landia.dk)

UK subsidiary:  
Landia (UK) Ltd.  
Waymills Industrial Estate,  
Whitchurch,  
Shropshire SY13 1TT  
Tel: + 44 01948 661 200  
[info@landia.co.uk](mailto:info@landia.co.uk)  
[www.landia.co.uk](http://www.landia.co.uk)

## Rating plate

	DK-6940 Lem St.		
Type	<input type="text"/>	3~mot.nr.	<input type="text"/>
	<input type="text"/> V		<input type="text"/> A
	<input type="text"/> Hz	<input type="text"/> kW	Ins.cl. <input type="text"/>
Cos φ	0, <input type="text"/>	<input type="text"/> RPM	<input type="text"/> kg
Eff. cl.	<input type="text"/>	Year	<input type="text"/>
	IP <input type="text"/>	Duty type	S1

Type:	Unit type
3~mot.nr.:	Serial no.
V:	Connection voltage, star/delta
A:	Nominal power consumption at full load
Hz:	Net frequency
kW:	Max. shaft power
Ins.cl.:	Insulation class
Cos φ:	Power factor
RPM:	Motor revolutions per minute
Kg:	Weight of unit
Eff. cl.:	Efficiency class
Year:	Year of manufacture
IP:	Cage class
Duty type S1	Continuous working period

The rating plate states the motor's electrical data as well as the year of manufacture and the serial no. (3~Mot.nr.). With regard to maintenance of a specific unit please state serial no. when contacting Landia.

### Please note

It is important that the electrical cable is tightened to prevent the cable from getting into contact with the propeller. The cable can be ensured against damage by means of a cable mesh or a chain.

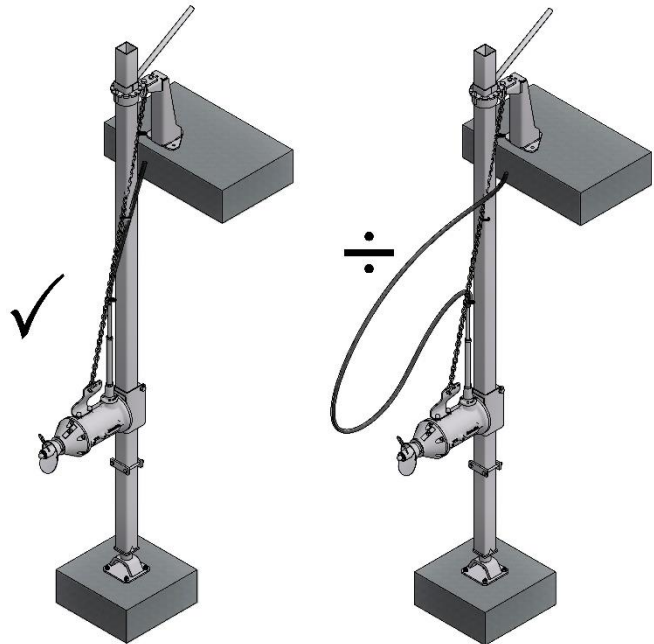

## Power connection

Every mixer is equipped with the above mentioned rating plate with technical motor data. It must be ensured that the other electrical parts correspond to the motor data. For each agitator there is an electrical diagram. A protective motor switch must be applied at connection of the mixer to the mains.

**Only a certified electrician is allowed to connect the unit.**

## Operation

The mixers have thermal sensors as standard equipment.

Often the mixers are exposed to extremely difficult operation conditions. Therefore, it is important to connect the thermal control. Burning of the motor due to overheating can thus be avoided. If the safety function has been activated the mixer must not be re-started until the cause of the disconnection has been found.

Among other things the disconnection can be caused by reduced mains voltage, a propeller blockage or an overheated motor. The cooling period for overheated motors can be up to 1 hour.

**The unit must not operate above liquid level**

## Capacity

The capacity of the mixer will always depend on the consistency of the medium, but especially on the design of the tank.

## Inspection

Regular inspection will ensure the mixer a long life at low costs. The oil must be changed every 4 months/2,500 hours of operation, however, min. once a year. Under difficult operation conditions, more often than every 4 months.

## Oil control

The oil is checked by removing the upper oil plug pos. A. The oil has to be clean and the level has to reach the level of the plug hole. Oil type: see spare parts list. If the oil is dirty, it must be changed.

- A. Top oil plug
- B. Lower oil plug
- C. Inspection screw

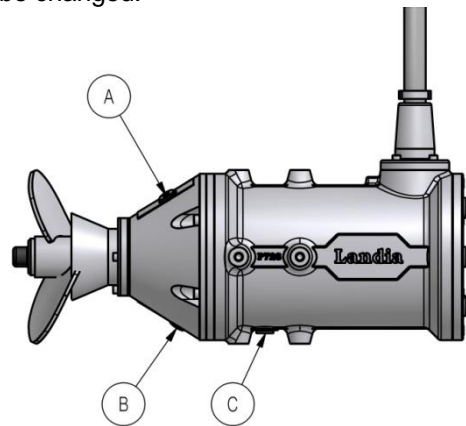

The oil is drained off by removing the plugs pos. A and pos. B. If the oil is dirty, the outer seal must be checked for wear and contamination. Oil is filled at oil plug pos. A.

The inner seal must be checked in the following way:

Remove the inspection plug pos. C beneath the motor. A small seepage of oil is normal. The oil quantity is checked by drainage pos. C.

In case of abnormal seepage, it is necessary to check the inner seal.

If it is necessary to dry up the motor windings, contact a special workshop.

## Equipment

The equipment should be checked for wear and corrosion. The winch is to be grease lubricated. Control brake and lock. Retighten screws. If the screws are loose remove them and lubricate with an adhesive substance (e.g. Loctite) prior to reinstallation.

## Disassembling/assembling the unit

Note a major repair should take place at a special workshop.

Below please find some general conditions regarding disassembling/assembling of Landia mixer type POD-I.

The drawing attached to the spare parts list shows the construction of the unit. Not all parts can/should be dismantled, e.g. do not press the rotor off the shaft.

When disassembling the unit, handle the mechanical seals with care as they are not shock resistant.

Prior to reinstallation, all sealing surfaces must be cleaned; all O-rings must be checked and changed, if necessary.

Adhesive substance (e.g. Loctite) must be applied on all bolt joints. All bolts are tightened with a tightening torque acc. to the table below.

Bolt sizes	Quality 10.9 - 12.9 Steel	Quality A4-80 Acidproof
M6	14 Nm	10 Nm
M8	34 Nm	24 Nm
M10	67 Nm	48 Nm
M12	115 Nm	82 Nm
M16	160 Nm	137 Nm

**Please note**

After installing the bearing flange, control the axial clearance; as stated in the table below.

Motor series	Acceptable clearance
ms80	0,7 ± 0,05 mm
ms90	0,7 ± 0,05 mm
ms100	0,9 ± 0,05 mm
ms112	1,0 ± 0,05 mm
ms132	1,0 ± 0,05 mm
ms160	1,1 ± 0,05 mm

A. Bearing flange



**Installation of mechanical shaft seals**

When installing the mechanical shaft seals please be aware that these are precision products and that they should be treated as such. The slide faces must be protected during the installation.

- B: Stationary sealing part
- C: Rotating sealing part
- D: Locking ring
- E: Shaft

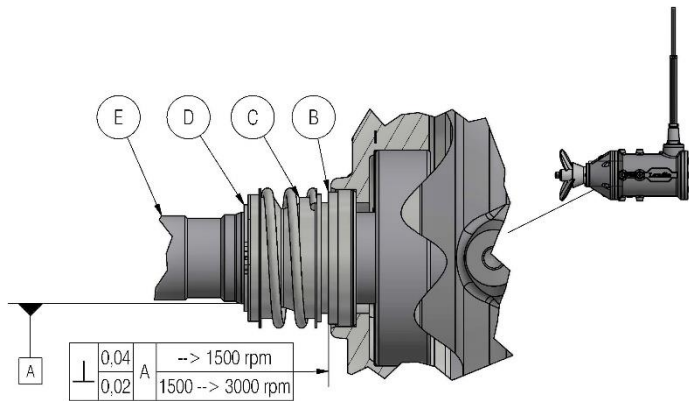

Push the stationary sealing part (pos. B) into place. Be careful not to damage the slide face during the installation. When the stationary part is mounted and straightened with a dial gauge, wipe it off with degreaser.

The rotating sealing part (pos. C) is put over the shaft. To ease the installation put soap water on the interior side of the rubber bellows as well as on the shaft. Do not apply silicone, PTFE lubricants or oil as they will prevent the rubber bellows from sticking to the shaft. Installation arbor should be used. Put the locking ring (pos. D) on the shaft and press together the seal until the locking ring snaps into the locking ring trace. Control the seal by turning the motor shaft.

Test the mixer for leakage by submerging it and by putting the motor casing and the oil chamber under an overpressure. The overpressure is to be approx. 1 bar. Leakage (air bubbles) must not appear. Oil is filled in the oil chamber. During the filling the mixer must be in a horizontal position. Oil quantity: see spare parts list.

Repair of surface coating, if any, is necessary prior to operation start. See instruction for maintenance of surface coating.

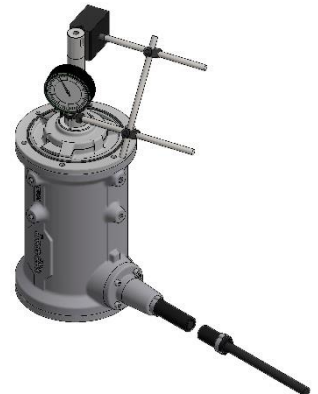

## Table of contents

Introduction .....	2
Application.....	2
Warning.....	2
Service/repair .....	2
Rating plate .....	4
Power connection.....	4
Operation .....	4
Capacity .....	5
Inspection.....	5
Equipment .....	5
Disassembling/assembling the unit.....	5

## Introduction

PODR-I is a horizontal submersible mixer. All surfaces which are in contact with the medium are made of stainless steel.

The unit is placed in the cross section of the liquid to obtain the required mixing. During operation the mixer is locked by the guide pipe to obtain stability. The mixing takes place by means of an electric motor; a propeller is installed on the motor shaft.

The oil filled oil chamber between motor and propeller provides cooling and lubrication of the mechanical seals. The sealing system consists of two mechanical seals. The exterior seal separates the medium from the oil chamber; the interior seal separates the oil from the motor casing. The following pages describe the connection and the maintenance of mixers type PODR-I.

## Application

This mixer is to be used for flow creation, mixing and homogenization of liquids with a high or low dry matter content, like e.g. wastewater, sludge, and paper pulp, as well as chemical liquids and manure.

The mixer can be placed in square and circular tanks and is to be applied only fully submerged below liquid level. If the mixer is to be applied for other purposes, contact Landia A/S for advice.

## Warning

Please note the following points:

- Only a certified electrician is allowed to connect the unit.
- Prior to installation and commissioning ensure that the equipment is installed correctly and fixed to the mixer, as well as ensure that the equipment in the tank is fixed safely.
- Prior to the first start of the mixer, the propeller shaft must be rotated manually. This also applies if the mixer has not been in operation for a longer period.
- The electrical cable is always to be tightened by means of the chain to prevent the cable from getting into contact with the propeller. If the mixer is not supplied with a chain, the cable is to be protected against damage in another way, e.g. by means of a cable mesh.
- It must be ensured that the propeller cannot touch the tank.
- It is always to be ensured that the mixer is fully below liquid level during operation.
- Prior to hoisting the mixer at service/repair it is always to be ensured that the electrical connection of the mixer is switched off or locked. Prior to service/repair the mixer should be cleaned thoroughly.
- When the mixer is hoisted or lowered, its cable and chain are always to be placed outside the work area.
- For service/repair of mixers installed in well/tank with explosion danger/toxic gases we refer to the national safety directions as far as safety is concerned, e.g. concerning the toxic hydrogen sulphide.

## Service/repair

To maintain a high operation safety and a long service life without unnecessary and expensive repair it is important from the beginning to execute regular and preventive service. Maintenance should be executed according to the intervals stated in the manual. Always follow the instruction carefully and only apply the parts described by Landia A/S in the spare parts list.

If you do not want to execute service yourself - we can offer you a service agreement - please call for further information.



**Please note**

If spare parts not identical to the recommended are applied at service/repair, the guarantee from Landia A/S will be annulled. Spare parts can be ordered at Landia A/S or your local distributor.

For major repairs at a special workshop please contact:

Head Office:  
LANDIA A/S  
Industrivej 2  
DK-6940 Lem St.  
Tel.: +45 97 341244  
[info@landia.dk](mailto:info@landia.dk)  
[www.landia.dk](http://www.landia.dk)

UK subsidiary:  
Landia (UK) Ltd.  
Waymills Industrial Estate,  
Whitchurch,  
Shropshire SY13 1TT  
Tel: + 44 01948 661 200  
[info@landia.co.uk](mailto:info@landia.co.uk)  
[www.landia.co.uk](http://www.landia.co.uk)

Landia A/S is represented by local distributors worldwide, please call for further information.

## Rating plate

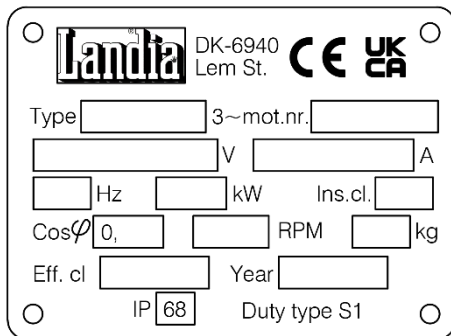

Type:	Unit type
3~mot.nr.:	Serial no.
V:	Connection voltage, star/delta
A:	Nominal power consumption at full load
Hz:	Net frequency
kW:	Max. shaft power
Ins.cl.:	Insulation class
Cos φ:	Power factor
RPM:	Motor revolutions per minute
Kg:	Weight of unit
Eff. cl.:	Efficiency class
Year:	Year of manufacture
IP:	Cage class
Duty type S1	Continuous working period

The rating plate states the motor's electrical data as well as the year of manufacture and the serial no. With regard to maintenance of a specific unit please state serial no. when contacting Landia.

### Please note

It is important that the electrical cable is tightened to prevent the cable from getting into contact with the propeller. The cable can be ensured against damage by means of a cable mesh or a chain.

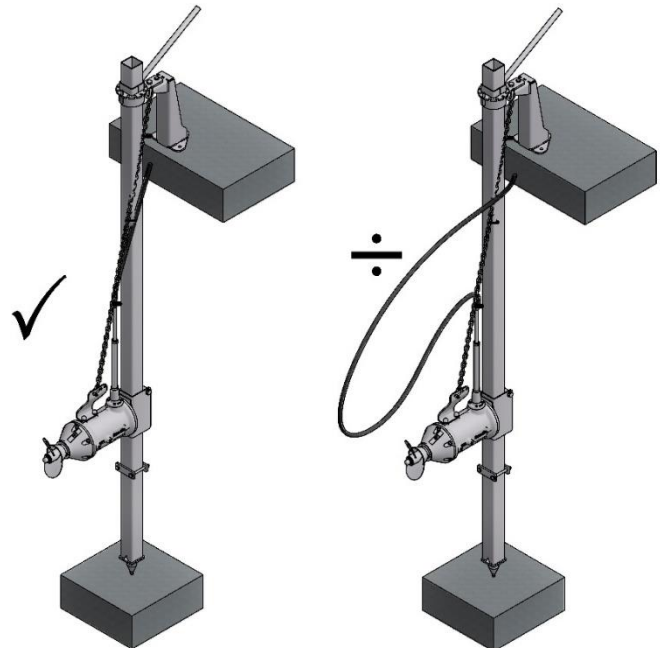

## Power connection

Every mixer is equipped with the above mentioned rating plate with technical motor data. It must be ensured that the other electrical parts correspond to the motor data. For each agitator there is an electrical diagram. A protective motor switch must be applied at connection of the mixer to the mains.

**Only a certified electrician is allowed to connect the unit.**

## Operation

The mixers have thermal sensors as standard equipment. Often the mixers are exposed to extremely difficult operation conditions. Therefore, it is important to connect the thermal control. Burning of the motor due to overheating can thus be avoided. If the safety function has been activated the agitator must not be re-started until the cause of the disconnection has been found.

Among other things the disconnection can be caused by reduced mains voltage, a propeller blockage or an overheated motor. The cooling period for overheated motors can be up to 1 hour.

**The unit must not operate above liquid level.**

## Capacity

The capacity of the mixer will always depend on the consistency of the medium, but especially on the design of the tank.

## Inspection

Regular inspection will ensure the mixer a long life at low costs. The oil must be changed every 4 months/2,500 hours of operation, however, min. once a year. Under difficult operation conditions, more often than every 4 months.

## Oil control

The oil is checked by removing the upper oil plug (pos. A). The oil has to be clean and the level has to reach the level of the plug hole. Oil type: see spare parts list. If the oil is dirty, it must be changed.

- A. Top oil plug
- B. Lower oil plug
- C. Inspection Screw

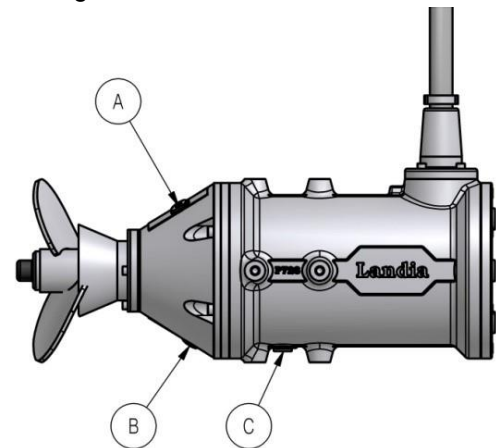

The oil is drained off by removing the plugs (pos. A and pos. B). If the oil is dirty, the outer seal must be checked for wear and contamination.

Oil is filled at oil plug (pos. A).

The inner seal must be checked in the following way:

Remove the inspection plug (pos. C) beneath the motor. A small seepage of oil is normal. The oil quantity is checked by drainage (pos. C).

In case of abnormal seepage, it is necessary to check the inner seal.

If it is necessary to dry up the motor windings, contact a special workshop.

## Equipment

The equipment should be checked for wear and corrosion. The winch is to be grease lubricated. Check brake and lock. Retighten screws. If the screws are loose, remove them and lubricate with an adhesive substance (e.g. Loctite) prior to reinstallation.

## Disassembling/assembling the unit

A major repair should take place at a special workshop.

Below please find some general conditions regarding disassembling/assembling of Landia mixer type PODR-I.

The drawing attached to the spare parts list shows the construction of the unit. Not all parts can/should be dismantled, e.g. do not press the rotor off the shaft.

When disassembling the unit, handle the mechanical seals with care as they are not shock resistant.

Prior to reinstallation, all sealing surfaces must be cleaned, all O-rings must be checked and changed, if necessary. Adhesive substance (e.g. Loctite) must be applied on all bolt joints. All bolts are tightened with a tightening torque acc. to the table below.

Bolt sizes	Quality 10.9 - 12.9 Steel	Quality A4-80 Acidproof
M6	14 Nm	10 Nm
M8	34 Nm	24 Nm
M10	67 Nm	48 Nm
M12	115 Nm	82 Nm
M16	160 Nm	137 Nm

**Please note**

After installing the bearing flange control the axial clearance as stated in the table below.

Motor series	Acceptable margin
ms100	0,9 ± 0,05 mm
ms132	1,2 ± 0,05 mm
ms160	1,2 ± 0,05 mm

A. Bearing flange

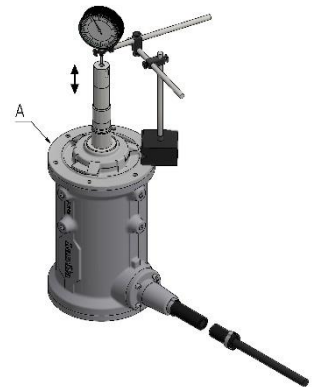

**Installation of mechanical shaft seals**

When installing the mechanical shaft seals please be aware that these are precision products and that they should be treated as such. The slide faces must be protected during installation.

- B. Stationary sealing part
- C. Rotary sealing member
- D. Locking ring
- E. Shaft

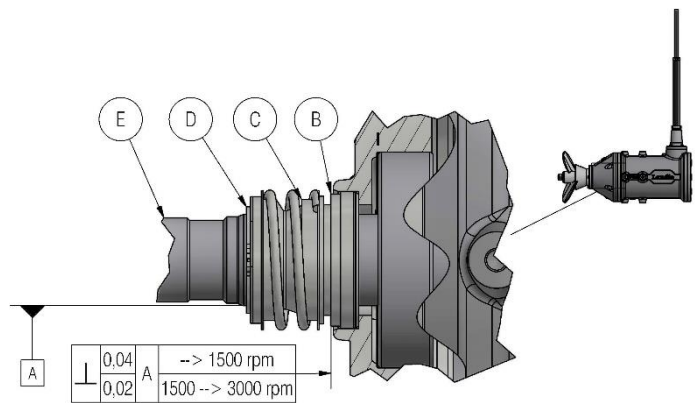

Push the stationary sealing part (pos. B) into place. Be careful not to damage the slide face during the installation. When the stationary part is mounted and straightened with a dial gauge, wipe it off with degreaser.

The rotating sealing part (pos. C) is put over the shaft. To ease the installation put soap water on the interior side of the rubber bellows as well as on the shaft. Do not apply silicone, PTFE lubricants or oil as they will prevent the rubber bellows from sticking to the shaft. Installation arbor should be used.

Put the locking ring (pos. D) on the shaft and press together the seal until the locking ring snaps into the locking ring trace. Check the seal by turning the motor shaft.

Test the mixer for leakage by submerging it and by putting the motor casing and the oil chamber under an overpressure. The overpressure is to be approx. 1 bar. Leakage (air bubbles) must not appear. Oil is filled in the oil chamber. During the filling, the mixer must not be in a horizontal position.

Oil quantity: see spare parts list.



## Oil Amount Table - Mixers

### POP-I

Type	Motor series	Gear	Medium temp.	Medium temp.	Seal Control	Grease	Food Industry	
			0-30°	30-60°			Nevastane EP 100 (9380024)	Nevastane SFG 2 (9380025)
POP-I	80/90	EM 1010	Alpha SP 100 (9380008)	Alpha SP 220 (9380002)	Alphasyn GS 220 (9380005)	Bel Ray 50-2 (9380012)	0.9 l	0.3 kg
	100/112	EM 1010	0.9 l		0.5 kg	1.1 l	0.5 kg	
	132	EM 1010	1.1 l			1.8 l	1.0 kg	
	132/160	EM 1020	1.8 l		3.0 l	1.0 kg		
	180	EM 1045	3.0 l		4.0 l	1.0 kg		
POPR-I	100	EM 1010	2.8 l		0.5 kg	2.8 l	0.5 kg	
	132	EM 1010	3.0 l			3.0 l		
	132/160	EM 1020	6.0 l		1.0 kg	6.0 l	1.0 kg	
	180	EM 1045				6.0 l		
POPTR-I POPTR-I Ex	-	EM 1010	5.3 l		0.5 kg	5.3 l	0.5 kg	
	-	EM 1020	9.3 l		1.0 kg	9.3 l	1.0 kg	

### POPL-I

Type	Motor series	Gear	Alpha SP 220 (9380002)	Seal Control	Grease
				Alphasyn GS 220 (9380005)	Bel Ray 50-2 (9380012)
POPL-I	90	ED 2030	2.3 l		0.5 kg
	100/112	ED 2030	3.0 l		
	112/132	ED 2045	4.0 l		

### POD-I

Type	Motor series	Rpm.	CRB Multi 15W-40 (9380001)	Hyspin HVI 15 (9380011)	Frequency Converter	Seal Control	Food Industry
					CRB Multi 15W-40 (9380001)	Hyspin HVI 46D (9380009)	Whitemore WOM 65 (9380015)
POD-I PODB-I	80/90	750/1000/1500	0.5 l		0.5 l		
	100/112		0.9 l		0.9 l		
	132/160		1.6 l		1.6 l		
PODR-I PODBR-I	100		0.5 l		0.5 l		
	132/160		1.2 l		1.2 l		
PODB-I	80/90	3000	-		0.5 l		
	100/112		-		0.9 l		
	132/160		-		1.6 l		
PODBR-I	100		-		0.5 l		
	132/160		-		1.2 l		
PODTR-I	-	750	3.5 l	-	3.5 l		

**AXD-I / AXP-I**

				Frequency Converter	Medium temp. 0-30°	Medium temp. 30-60°	Seal Control		Grease
Type	Motor series	Gear	CRB Multi 15W-40 (9380001)		Alpha SP 100 (9380008)	Alpha SP 220 (9380002)	Hyspin HVI 46D (9380009)	Alphasyn GS 220 (9380005)	Bel Ray 50-2 (9380012)
AXD-I 300	100/112	-	0.9 l		-		0.9 l	-	
	132		1.7 l				1.7 l		
AXP-I 500 AXP-I 800	90	EM 1010	-		0.9 l	-		0.9 l	0.3 kg
	100/112				1.1 l			1.1 l	0.5 kg
	132				1.8 l			1.8 l	
	132/160	EM 1020			3.0 l			3.0 l	1.0 kg

**Konverteringsskema - Conversion table – Umrechnungstabelle - Tableau concernant****Olie - Oil - Öl**

CASTROL	Alpha SP 100	Alpha SP 220	Whitemore WOM 65	CRB Multi 15W-40	Hyspin HVI 15	Hyspin HVI 46D	Nevastane EP 100	Alphasyn GS 220
<b>DIN-Norm / godkendelse</b>	DIN 51502/DIN 51517 - CLP	DIN 51502/DIN 51517 - CLP	Ingen alternativer - No alternatives - Keine Alternativen - Pas d'alternative	Ingen alternativer - No alternatives - Keine Alternativen - Pas d'alternative	DIN 51502/ DIN 51524 - HVLP	DIN 51502-HVLP-D/ DIN 51524 - CLP	Ingen alternativer – No alternatives - Keine Alternativen - Pas d'alternative	DIN 51502/ DIN 51517 - CLP PG

**Fedt - Grease - Fett - Graisse**

<b>BEL RAY</b>	Bel Ray 50-2
<b>CASTROL</b>	Tribol GR 4747/220-2 HT
<b>MOBIL</b>	Mobilgrease FM 222
<b>Q8</b>	Rubens WB
<b>SHELL</b>	SHELL GADUS S3 V220C 2
<b>TEXACO</b>	Anderol 783-2
<b>TOTAL</b>	TOTAL NEVASTANE XMF 2

Smøremidler, som anvendes og anbefales af Landia A/S, er markeret med gråt i ovenstående skemaer. Konverteringsskemaerne angiver DIN-Norm / godkendelse på olietyper fra Castrol. DIN-Normen fra Castrol er vejledende og kan bruges til at finde en erstatningsolie hos Deres lokale olieleverandør. Hvis det ikke er muligt at finde en erstatningsolie, kan olien købes hos Landia A/S. Generelt bør blanding af forskellige fedttyper undgås enten ved udskiftning af al fedtet eller hyppig eftersmøring, så fedtet hurtigt udskiftes. Fedttyperne angivet ovenfor er blandbare.

Lubricants applied and recommended by Landia A/S are marked with grey in the above tables. The conversion schemes indicate the DIN Norms and the approved oil types from Castrol. The DIN Norm from Castrol is indicative and can be used to find a replacement oil from your local oil supplier. If it is not possible to find a replacement oil, the oil can be purchased from Landia A/S. Generally, mixing of different types of grease should be avoided either by replacing all the grease or frequent lubrication, so the grease is quickly replaced. The grease types mentioned above are mixable.

Das von Landia A/S empfohlene Schmiermittel, das verwendet werden muss ist in oben stehendem Schema mit grau markiert. Die Konvertierungsschemas zeigen die DIN-Normen und eine Übersicht der zugelassenen Öltypen von Castrol. Die DIN-Normen von Castrol sind indikativ und kann verwendet werden, um ein Ersatzöl von Ihrem lokalen Öllieferanten zu finden. Wenn es nicht möglich ist, ein Ersatzöl zu finden, kann das Öl von Landia A / S gekauft werden. Im Allgemeinen sollte Mischung von verschiedenen Schmiermitteln vermieden werden. Entweder das Fett wechseln oder häufig nachschmieren. Die oben genannte Fedttyper sind mischbar.

Les lubrifiants utilisés et recommandés par Landia A/S sont marqués d'un cri dans les tableaux ci-dessus. Les tableaux de conversion indiquent la norme DIN/approbation pour les types d'huile de Castrol. La norme DIN de Castrol est indicative et peut être utilisée pour trouver une huile de remplacement chez votre fournisseur d'huile local. S'il n'est pas possible de trouver une huile de remplacement, l'huile peut être acheté auprès de Landia. En général, il convient d'éviter de mélanger différents types de graisses en remplaçant toutes les graisses ou toutes les post-lubrifications fréquentes de manière à remplacer rapidement les graisses. Les types de graisse mentionnés ci-dessus sont miscibles.

**Motordata for Landia motorer IE1**
**Side 1/1**
**3 x 400 Volt 50 Hz**

Effekt kW	ms.	Poltal	RPM	Spænding trekant	Spænding stjerne	Strøm ved 3x400 V A	Strøm ved 3x690 A	Starts. direkte A	Cos phi %	Virk. grad fuld last %	Virk. grad 3/4 last %	Virk. grad 1/2 last %
1,5	80	2	2840	230	400	3,1	0	22	0,86	81,2	82,2	80,3
2,2	80	2	2850	230	400	4,6	0	34	0,85	82,1	83,4	81,9
3	90	2	2865	400	690	6,2	3,6	42	0,85	82,8	83,1	83,3
4	100	2	2900	400	690	8,4	4,9	59	0,81	84,9	85,5	84,4
5,5	100	2	2860	400	690	11	6,2	61	0,86	84,7	84,7	0
7,5	112	2	2890	400	690	15	8,6	99	0,85	86,1	86,1	84,1
11	132	2	2905	400	690	20,5	12	143	0,88	87,6	87,6	84,6
15	160	2	2940	400	690	27,5	16	195	0,89	88,7	88,7	85,8
18,5	160	2	2925	400	690	33	19,5	238	0,9	89,9	88,9	86,4
22	180	2	2935	400	690	39	22,5	265	0,9	90,5	90,5	86,7
30	180	2	2940	400	690	52,5	30,5	383	0,91	90,6	89,8	88,3
37		2	2940	400	690	65	37,50	455	0,9	91,5	90,5	89
45		2	2940	400	690	77,5	44,7	581	0,91	92	91,3	88,8
0,55	71	4	1400	230	400	1,6	0	7	0,69	71,9	70,7	64,1
0,75	71	4	1400	230	400	2,1	0	10	0,7	73,6	72,2	66,8
1,1	80	4	1410	230	400	2,6	0	14	0,79	76,7	76,8	73,6
1,5	80	4	1400	230	400	3,4	0	19	0,81	78,6	79,1	76,9
2,2	90	4	1410	230	400	5	0	30	0,8	80,2	80,7	79,5
3	100	4	1430	400	690	6,7	3,9	43	0,79	82,4	82,8	80,8
4	100	4	1435	400	690	8,8	5,1	61	0,78	84,1	85,1	83,6
5,5	112	4	1440	400	690	11	6,2	68	0,87	84,6	84,6	83,1
7,5	132	4	1455	400	690	15	8,8	90	0,83	86,2	85,2	83,8
11	131	4	1455	400	690	21,5	12,5	146	0,84	87,9	87,5	85,5
15	160	4	1465	400	690	29	17,00	212	0,84	88,7	88,3	85,8
18,5	160	4	1460	400	690	35	20,5	238	0,85	89,3	88,8	86,8
22	180	4	1465	400	690	43	25	280	0,82	90,1	90,1	88,6
30	180	4	1465	400	690	57	33	399	0,84	90,7	90,2	89,2
37		4	1470	400	690	68	39,2	476	0,86	91,2	90,2	89,2
45		4	1470	400	690	82,5	47,6	578	0,86	91,7	91,2	89,7
0,55	50	8	695	230	400	2	0	7	0,6	64,8	62,5	55,8
0,75	50	8	705	230	400	2,7	0	9	0,6	66,8	64,7	57,9
1,1	50	8	705	230	400	3,3	0	13	0,67	72,9	73,3	69,6
1,5	50	8	705	230	400	4,1	0	18	0,7	75,4	75,7	72,4
2,2	50	8	705	230	400	5,6	0	25	0,75	75,6	75,1	72,1
3	50	8	705	400	690	7,4	4,3	33	0,75	78	78	75
4	50	8	710	400	690	9,3	5	37	0,78	79,6	79,3	77,3
5,5	50	8	710	400	690	12,5	7,2	56	0,78	81,4	81	78
7,5	50	8	725	400	690	18	10,5	81	0,71	84,7	84,7	81,7
11	50	8	720	400	690	24	14	108	0,78	84,8	83,8	81,3



**Motordata for Landia motorer IE2**
**Side 1/1**
**3 x 400 Volt 50 Hz**

Effekt kW	ms.	Poltal	N rpm	Spænding trekant V	Spænding stjerne V	Strøm ved 3x400 V A	Strøm ved 3x690 A	Starts. direkte A	Cos phi $\phi$	Virk. grad fuld last %	Virk. grad 3/4 last %	Virk. grad 1/2 last %
1,5	90	2	2910	230	400	2,9	0	34	0,87	81,3	85,5	82,9
2,2	90	2	2880	230	400	4,25	0	34	0,88	83,2	85,7	83,9
3	100	2	2930	400	690	6,55	3,8	56	0,76	84,6	86,2	83,5
4	100	2	2920	400	690	7,9	4,6	66	0,84	85,8	86,4	85,8
5,5	112	2	2900	400	690	10,3	5,9	80	0,88	87	88,7	88,8
7,5	132	2	2925	400	690	13,5	7,8	90	0,91	88,8	89,2	88,3
11	160	2	2950	400	690	19,5	11,3	150	0,9	90,3	90,3	89,1
15	160	2	2940	400	690	26	15,0	230	0,92	90,7	90,5	89,1
18,5	160	2	2935	400	690	32	18,5	230	0,91	91	91,4	91,4
22	180	2	2935	400	690	38,5	22,2	239	0,9	91,3	90,6	86,4
30	180	2	2945	400	690	52	30,0	359	0,91	92	91,3	90,5
37	180	2	2940	400	690	63	36,4	466	0,92	92,5	92,3	91,6
0,55	80	4	1430	230	400	1,25	0	8	0,8	79,4	79,6	78,7
0,75	80	4	1430	230	400	1,65	0	12	0,81	79,6	81,4	79,6
1,1	90	4	1435	230	400	2,4	0	16	0,8	81,4	82,3	80,4
1,5	100	4	1455	230	400	3,35	0	45	0,77	82,8	83,2	80,7
2,2	100	4	1455	230	400	4,8	0	45	0,77	84,3	85,2	81,7
3	112	4	1460	400	690	6,5	3,8	63	0,77	85,5	86,3	84,5
4	112	4	1460	400	690	7,6	4,4	63	0,86	87,6	88	86,9
5,5	132	4	1470	400	690	10,5	6,1	123	0,87	88,4	89,3	89
7,5	132	4	1470	400	690	14,5	8,4	123	0,82	89,9	90	88,5
11	160	4	1470	400	690	22,5	13,0	176	0,78	90,3	90,3	88,9
15	180	4	1475	400	690	28,5	16,5	307	0,83	91	90,4	89
18,5	180	4	1475	400	690	35,5	20,5	307	0,82	91,2	90,6	89,3
22	180	4	1475	400	690	42	24,2	307	0,83	91,6	91,4	89,9
0,55	80	6	950	230	400	1,5	0	6	0,69	76,5	76,1	72,6
0,75	90	6	955	230	400	1,95	0	10	0,71	75,9	78,3	75,1
1,1	100	6	955	230	400	2,75	0	15	0,71	78,1	82	79,3
1,5	112	6	955	400	690	3,55	0	50	0,75	81	80,5	79,6
2,2	112	6	955	400	690	5,2	0	50	0,74	82,8	82,5	80
3	112	6	955	400	690	7,1	4,1	50	0,73	83,3	83,1	80,5
4	132	6	965	400	690	8,5	4,9	43	0,79	85,5	85,5	83,8
5,5	160	6	970	400	690	12	6,9	91	0,76	87	86,4	85,8
7,5	160	6	970	400	690	15,5	8,9	91	0,79	87,5	87,6	85,9
11	180	6	975	400	690	21	12,1	177	0,84	89,2	87,9	86,3
15	180	6	975	400	690	28,5	16,5	177	0,84	89,7	88,8	86,7
18,5	180	6	980	400	690	35	20,2	231	0,85	90,4	88,8	86,5

**Motordata for Landia motorer IE3**

Side 1/1

**3 x 400 Volt 50 Hz**

Effekt	ms.	Poltal	N	Spænding trekant	Spænding stjerne	Strøm ved 3x400 V	Strøm ved 3x690	Starts. direkte	Cos phi	Virk. grad fuld last	Virk. grad 3/4 last	Virk. grad 1/2 last
kW			rpm	V	V	A	A	A	$\varphi$	%	%	%
1,5	100	4	1455	230	400	3,4	-	32,3	0,75	85,3	84	80,6
4	112	4	1465	400	690	7,9	4,6	74,3	0,82	88,6	88,9	87,4
7,5	132	4	1470	400	690	16	9,2	121,6	0,75	90,5	90,5	89,2
11	160	4	1465	400	690	21	12,1	147	0,82	91,4	91,4	91,5
18,5	180	4	1475	400	690	34,5	19,9	269,1	0,84	92,6	92,7	91,9
4	132	6	965	400	690	8,3	4,8	39,9	0,8	86,8	87	86
7,5	160	6	975	400	690	14,5	8,4	84,1	0,82	89,6	89,4	87,8